

COMBI 250 VA

SAWING MACHINE

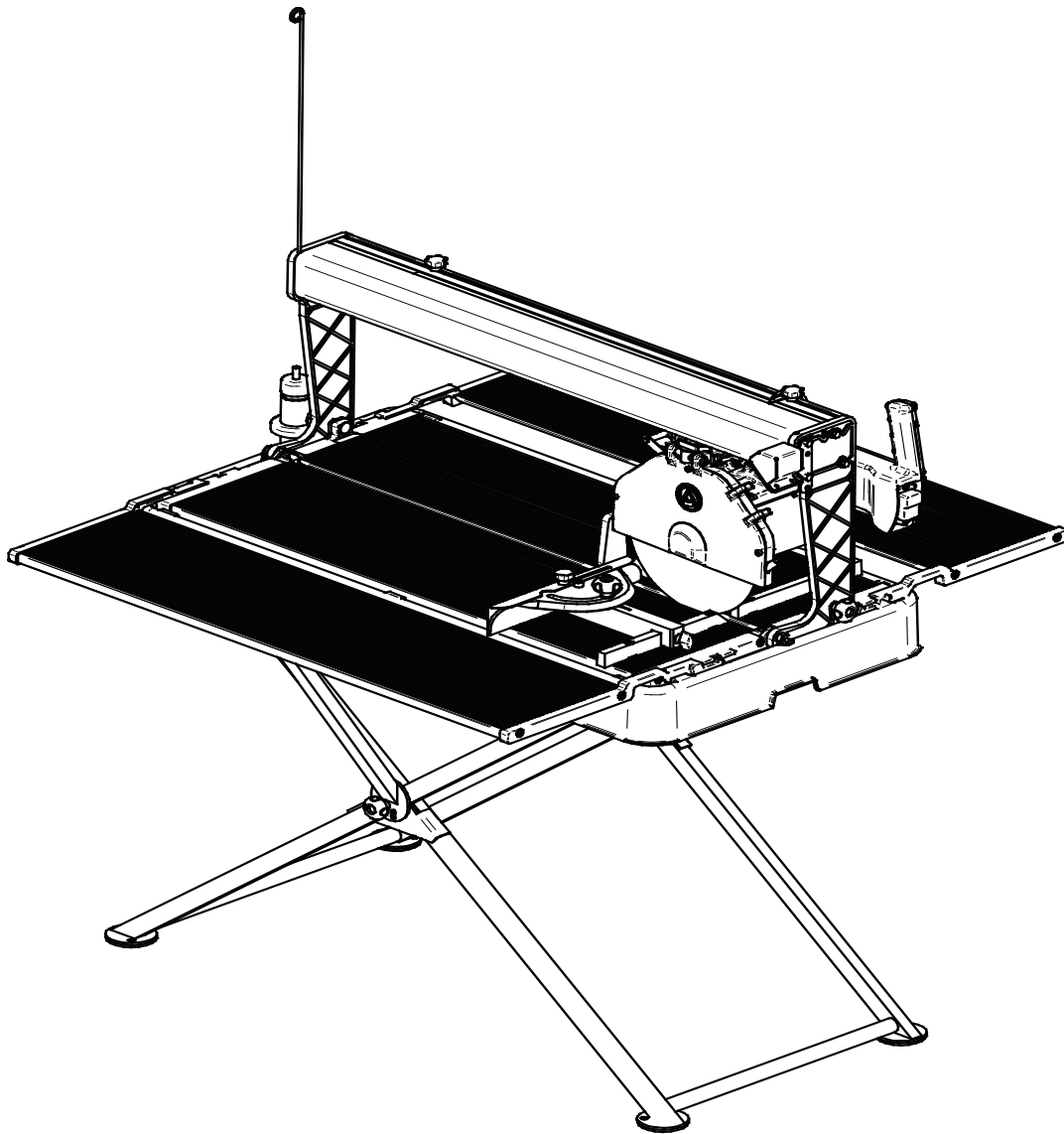

OPERATING, MAINTENANCE, SPARE PARTS MANUAL

IMER U.S.A. Inc.

Toll Free: 800.275.5463

www.imerusa.com

info@imerusa.com

IMER WEST

3654, Enterprise Avenue
Hayward, CA 94545
Ph. 510.670.7970
Fax 510.783.4255

IMER EAST

221 Westhampton Place
Capitol Heights, MD 20743
Ph. 301.336.3700
Fax 301.336.6687

2015/09 - R05

Cod. 3226143

Dear Customer,
Congratulations on your choice of purchase: IMER saws are the result of years of experience and are equipped with all the latest technical innovations.

! - WORKING IN SAFETY

To work in complete safety, read the following instructions carefully.

To work in complete safety, read the following instructions carefully before using the machine.

To work in complete safety, read the following instructions carefully before using the machine.

This OPERATION AND MAINTENANCE manual must be kept on site by the person in charge, e.g. the SITE FOREMAN, and must always be available for consultation.

The manual is to be considered integral part of the machine and must be kept for future reference (EN 12100-2) until the machine is disposed of. If the manual is damaged or lost, a replacement may be requested from the manufacturer.

The manual contains important information regarding site preparation, machine use, maintenance procedures, and requests for spare parts.

Nevertheless, the installer and the operator must both have adequate experience and knowledge of the machine prior to use.

To guarantee complete safety of the operator, safe operation and long life of equipment, follow the instructions in this manual carefully, and observe all safety standards currently in force for the prevention of accidents at work (use of safety footwear and suitable clothing, helmets, gloves, goggles etc.).

! - Make sure that all signs are legible.

! - It is strictly forbidden to carry out any form of modification to the steel structure or working parts of the machine.

IMER INTERNATIONAL declines all responsibility for failure to comply with laws and standards governing the use of this equipment, in particular; improper use, defective power supply, lack of maintenance, unauthorised modifications, and partial or total failure to observe the instructions contained in this manual.

IMER INTERNATIONAL reserves the right to modify features of the saw and contents of this manual, without the obligation to update previous machines and/or manuals.

1. TECHNICAL DATA

Technical data are stated in table 1 and electrical specifications in table 2.

| Table 1 - TECHNICAL DATA | |
|--------------------------------------|-----------------|
| Model | Combi 250 VA |
| Max. blade diameter | 10 inches |
| Diamond Blade hole diameter | 5/8 inches |
| Single phase 115V/60Hz motor power | 1.3 kW |
| Max. blade rotation speed | 3.400 rpm |
| Cutting table dimensions | 850x500 mm |
| Length of 90° cuts (thickness= 10mm) | 550 mm |
| Length of cuts from above | 600 mm |
| Maximum cut depth with single stroke | 66 mm |
| Maximum cut depth with two stroke | 105 mm |
| Water pump flow rate | 13 L/1' |
| Water tank capacity | 36 L |
| Machine dimensions | 1050x565x480 mm |
| Packed machine dimensions | 1090x610x525 mm |
| Weight with packaging | 45.5 Kg |

| Table 2 | |
|----------------------|-------------------|
| Feature | Motor (115V/60Hz) |
| Power (kW) | 1.3 |
| Rated voltage (V) | 115 |
| Frequency (Hz) | 60 |
| Absorbed current (A) | 14.4 |
| Number of poles | 2 |
| rpm | 3400 |
| Service type | S6 40% |
| Insulation category | F |
| Protection category | IP55 |
| Capacitor (µF) | 110 (Ø 50x120) |

2. DESIGN STANDARDS

Combi 250 VA saws have been designed and manufactured according to the following standards: UNI EN 12418:2001; EN 12100-1/2:2005; EN 60204-1:2006.

3. SOUND PRESSURE LEVEL AND VIBRATIONS

Table 3 shows the sound pressure level measured loadless at the operator's ear (L_{pA}) and of the vibrations transmitted during operation.

| Table 3 | | | |
|--------------|---------------|----------|-----------------------|
| Model | Type of motor | L_{pA} | A_{vq} |
| Combi 250 VA | Electric | 86 dB | 2.57 m/s ² |

4. GENERAL SAW DESCRIPTION

4.1 General description

The Combi 250 VA is a saw comprising the following main sub-groups:

- cutter head (ref.A, fig.1)
- runner guide and arms (ref.B, fig.1)
- cutting tables and heads (ref.C, fig.1)
- water collection tank (ref.D, fig.1)
- frame (ref.E, fig.1)

The cutting head is mounted on a reinforced aluminium profile and is equipped with horizontal and vertical movement facilities. The aluminium profile is hinged onto die-cast arms (ref.F, fig.1) and the entire unit can rotate through 45° (fig.2) by means of the relative handwheels (ref.G, fig.2).

The machine is supported by a special metallic frame. There is a shockproof plastic tank between the machine and the frame. The water immersion pump is mounted below the cutting surfaces on a special bracket and supplies a water distributor inside the blade guard for cooling the cutting blade during operation.

The high resistance plastic handle (ref.H, fig.2), is equipped with the main ON-OFF switch on the operator side to facilitate saw activation and shutdown. The raised position of the red OFF button on the handle is designed to facilitate shutdown of the machine in the event of an emergency. The motor capacitor is located in a protected position inside the handle.

The saw is fitted with a guard to guarantee optimal safety during operation and to protect the user during cutting cycles.

A valve is mounted above the blade guard to adjust the flow rate of water delivered to the cutting blade.

4.2 Processable materials

This saw has been designed for cutting the following materials: ceramic tiles, masonry and stone in general with maximum dimensions compatible with the length, cutting depth and dimensions of the surfaces specified in table 1.

Maximum weight of processable materials: 25 kg.

4.3 Unsuitable material

Materials unsuitable for this machine are all those not specified in paragraph 4.2.

In any event, before using the saw with materials other than as specified by the manufacturer for this saw model, contact IMER INTERNATIONAL S.p.A.

! - Use of this machine with workpieces outside the specified dimensions is strictly prohibited and constitutes a hazard for the operator.

5. OPERATION SAFETY

 - Before using the saw, ensure that all protection devices are fitted.

 - Never use the saw in environments subject to the risk of explosions or fire.

The saw is not fitted with specific lighting and therefore the workplace must be sufficiently lit for this purpose (min. 300 lux).

The power lines must be laid to prevent any possible damage.

Ensure that the electrical connection is protected against the risk of water penetration in connectors. Use exclusively connectors and couplings equipped with water spray protection.

Never use inadequate or makeshift electrical lines or cables without earthing; if in doubt consult a specialised technician.

Repairs to the electrical circuit must be performed exclusively by specialised personnel. Disconnect the machine from the power supply before performing maintenance or repairs.

6. GENERAL SAFETY WARNINGS

Note that this machine has been designed to ensure optimal performance and maximum safety: however the operator must also guarantee this level of safety by paying special attention to the machine throughout all work phases.

1. Ensure that an efficient earthing system is installed.
2. Work only with all protection devices fitted correctly and in efficient working order.
3. Remove rings, watches, bracelets or ties before using the machine; these elements constitute a serious hazard to the operator. Also ensure that sleeves are tight around the wrists, hair is tied back and robust footwear is used.
4. Always use personal protection devices such as safety goggles, suitably sized gloves, ear muffs or plugs and hair caps when necessary.
5. Never cut workpieces that have dimensions or weight that are not suited to machine capacity as specified by the manufacturer (see point 4.2)
6. Always keep your hands away from the work areas when the machine is running. Before taking any action to remove a piece from close to the disc, stop rotation by pressing the stop button.
7. Keep the machine clean: general cleaning (and the work surfaces in particular) represents an important safety factor.
8. Always stop the machine and disconnect from the power supply before cleaning or removing any protection device (for maintenance or disassembly purposes). If water jets are used for cleaning, never point jets directly at the power supply unit or electric motor.
9. Use genuine diamond blades as recommended by the manufacturer to ensure optimal performance of the machine.
10. Use exclusively water-cooled continuous rim blades suited to the material to be cut.
11. Never dry cut material or cut when cooling water levels are low.
12. Never use blades over the rotation speed specified by the manufacturer.
13. Do not use reduction rings to adapt the hole of the disc on the flange. Only use discs with hole corresponding to the flange supplied with the machine (1" or 7/8").
14. Never use diamond blades that are chipped or deformed.
15. The instructions in this manual are aimed at machine users (operators, maintenance engineers).

7. SAFETY DEVICES

The Combi 250 VA has been constructed taking into account current harmonised European safety standards.

According to machine directive 98/37/EEC all safety devices have been installed with the aim of safeguarding the operator.

7.1 Guards and safety devices

The machine is equipped with fixed guards, secured by means of screws and protections that prevent access to moving or dangerous parts.

All fixed guards, covers, shields fixed by means of screws have been envisaged to protect the operator (maintenance engineers, technicians and others) from possible accidents caused by electrical discharge or moving mechanical parts.

Therefore use of the machine with guards removed or modified in any way is strictly prohibited.

 - Before performing maintenance or repairs to the machine, turn it off via the main switch and disconnect from the power supply to prevent inadvertent start-up and isolate all machine electrical circuits.

8. MACHINE INSTALLATION

8.1 Positioning

The machine must be placed on a smooth surface that is at least as large as the tank, with the saw on the relative stand.

 - Ensure that the stand is positioned on the relative inserts on the tank base and thus secured.

In the event of moving the saw, take care to secure the head by means of the fixing knobs (ref.L, fig.1) and carry the machine by means of the handles on the tank (ref.I, fig.1) after disconnecting the power supply.

 - Always remove the plug from the mains power before moving the machine.

8.2 Stand assembly

The stand is supplied disassembled. Firstly, join the two parts of each leg making sure that the inner and outer holes are aligned. Join the two legs fitting the safety catches (ref.3-4, fig. 6), tighten the screws and self-locking nuts with the spanner provided (ref.6, fig.6) taking care to allow rotation of the legs.

8.3 Lifting and handling

The Combi 250 VA saw weighs 33 Kg and can be moved by means of the side handles on the tank (ref.I, fig.1).

 - Always empty the tank before moving the machine.

8.4 Side roller assembling (optional kit p/n 1188166)

The side roller table is supplied with side supports already assembled.

First of all it's necessary to fit such supports

inside the proper seats housed alongside the saw up to the stop. Now lower the side roller table up it's levelled to the saw's table (fig.7).

To fit the central support it's necessary to reverse the screw fitting side of the stand which is aside the side roller table (ref.8, fig.7). Then place the support, fitting it inside the screw and tighten it so to hold the table. Then tighten the nut.

9. ELECTRICAL CONNECTION

 - Ensure that voltage corresponds to machine dataplate specifications.

The power supply line must be equipped with current overload protection (e.g. thermal cutout) and protection against indirect contact (e.g. residual current circuit breaker).

Connect the machine to an efficient earthing system.

The size of the power cable wires must be based on operating current and length of the power line to prevent excessive voltage drops (table 4).

| Model | Type of motor | Cable (mm ²) | | | Cable length (m) |
|--------------|-----------------|--------------------------|---------|---------|------------------|
| | | 1.5 | 2.5 | 4.0 | |
| Combi 250 VA | 115 V 14.4 A | 0 ÷ 12 | 13 ÷ 20 | 21 ÷ 32 | |

Connect the saw plug to the mains and tighten the mechanical retainer ring with IP67 protection rating.

The saw is now ready for operation.

10. MACHINE USE

10.1 Operation

The correct side for the operator is shown in fig.4 ref.X.

Fill the water tank to the maximum level (approx. 36 litres).

Connect the machine to the power mains and start as described in paragraph 10.

Open the valve (ref.N, fig.1) and ensure sufficient flow of cooling water to the diamond blade.

10.2 Cutting

Rest the material to be cut on the cutting table against the stopper. Define the required inclination using the goniometer. To adjust the cutting head height, loosen the handwheel (ref.O, fig.3), position the head at the required height, then fully tighten the handwheel. Make sure that handwheels for sloped cutting (ref.G, fig.2) are firmly tightened. Start the sawing machine as described in paragraph 10. To proceed with cutting, press the piece to be cut on the table with your hand and move the cutter head gripping the handle and drawing it towards you. If the feed speed is too fast in relation to the thickness and hardness of the material the blade might stop turning. In this case, release the disk as quickly as possible moving the cutter head away from you until the disk recovers its nominal rotation speed. Resume cutting, adjusting the feed speed according to the characteristics of the material.

10.3 Angled cuts

Loosen the handwheels (ref.G, fig.2), set the cutting head at the required angle, retighten the handwheels, and proceed as described in the point above.

 - Ensure that the tank is kept full during all work phases and in the event of prolonged work intervals replace water regularly and remove all processing residue.

10.4 Laser pointer

The machine is fitted with a laser pointer that reproduces the cutting line on the piece being machined. The track of light indicates the trajectory of the diamond disk during the feed motion. Making the required cutting profile coincide with the laser profile, it is possible to ensure the highest accuracy of the operation.

Cuts at right angle with one side of the piece being machined do not require tracing beforehand: in fact it will suffice to make sure that the side of reference is in contact with the stopper on the resting surface. Likewise, using the goniometer, cutting at predefined inclinations is possible. The laser light will indicate the actual position of the cut.

The laser pointer is activated when the machine is connected to the electric mains.

The pointer is aligned with the disk and must not be moved from its initial position.

 - The pointer used emits a low power laser light, but it is in any case advisable to avoid looking directly at the emitter itself.

11. MAINTENANCE

11.1 Premise

Routine maintenance operations can also be performed by non-specialised personnel provided that all safety standards specified in the relative sections of this manual are observed at all times.

11.2 Machine cleaning

The machine should be cleaned exclusively when it is stationary.

 - All power switches must be set to "0" and plugs must be disconnected from the mains.

1. Never use compressed air; this could cause infiltration of dust or residue in enclosed parts.
2. Ensure that the cooling water nozzles are not obstructed.
3. Above all the cooling water in the tank must be changed every day.
4. Do not use detergents or lubricants.

11.3 Cleaning the tank

Clean the tank in the event of build-up of sediment on the base, or at least once a day. Failure to clean the tank could impair operation of the immersion pump used for circulation of the diamond blade cooling water. To clean the tank, disassemble from the machine, lock the head, hold it by the arms and rinse with a direct water jet (this is to avoid direct contact of the water with electrical parts), the proceed with manual cleaning using cloths or brushes.

Take care not to damage cables when replacing the machine on the tank. Take care not to damage the pump when placing the machine on the surface.

11.4 Cleaning the cooling water supply circuit

At regular intervals (or when the flow rate of the blade cooling water is reduced) clean the cooling water supply circuit. To do this, disassemble the delivery nozzle (ref.P, fig.1) located inside the blade guard and clean in water.

Periodically clean the cooling water delivery line between the pump and valve and blade guard using water.

11.5 Blade replacement

The diamond blade is made of material that may be damaged when subject to high temperatures, and therefore must be cooled during the work phases.

To replace the blade, proceed as follows:

1. Block axial movement of the cutting head by means of the handwheels (ref.L, fig.1).
2. Disassemble the front guard (ref.P, fig.1).
3. Loosen the locknut by rotating clockwise (left thread), using a 19 mm wrench.
4. Move the cutting head forward slightly and incline to remove the blade from its seat.
5. Ensure that there are no foreign objects between the fixing flange and diamond blade. During disassembly, avoid use of tools that could dent or deform the flange.
6. Insert the new blade proceeding in reverse order of the operation described at point 4. Take special care to ensure correct direction of rotation of the diamond blade.
7. Tighten the blade locknut fully down by rotating anticlockwise (left thread), to a torque of 40 Nm.

 - Always disconnect the power plug before changing the disk.

11.6 Repairs

Repairs to the electrical installation must be performed exclusively by specialised personnel. Use exclusively original IMER spare parts; modifications to parts are strictly prohibited. The special design of the Combi 250 VA ensures that no other maintenance other than as specified above is required.

Ensure that the contacts of the power plug and plug-switch assembly are efficient. If oxidation is detected, clean immediately.

 - In the event of activation of the RCCB, check the machine and arrange for repairs if necessary exclusively by specialised personnel.

11.7 Waste disposal

As regards disposal of processing waste observe all current legislation in the country of use.

12. RESIDUAL RISKS AND SAFETY SIGNS

Although the sawing machine has been manufactured fully in compliance with current regulations, residual risks exist that cannot be eliminated and involve the use of appropriate individual protection devices. Adequate warning signs fitted on the machine point out both the risks and the behaviour to be followed.

NOISE RISK



Ear protection must be worn

RISK OF INJURY TO THE HANDS



Safety gloves must be worn

RISK OF INJURY TO THE EYES



Eye protection must be worn

ABNORMAL USE RISK



Reading the manual before use is compulsory



Cutting with water is compulsory

DANGER OF CUTTING



DANGER OF ELECTROCUTION



DANGER OF LASER BEAM



Please be reminded that checking the use of IPDs is delegated to the employer.

13. TROUBLESHOOTING

⚠ - CAUTION!!! All maintenance operations must be performed exclusively with the machine switched off, with the selector set to "0" and the power plug disconnected from the mains.

| Trouble | Causes | Remedies |
|---|---|--|
| The motor does not start when the start switch is pressed | Current does not reach the supply line | Check the line * |
| | The socket and plug are not connected properly | Restore correct connection |
| | The differential switch is off | Turn the differential switch on |
| | The power cable from the plug to the panel is cut off | Change the cable * |
| | An electric wire inside the motor terminal strip is cut off | Restore the connection * |
| | An electric wire inside the panel is cut off | Change the switch * |
| Cooling water fails to reach the blade | The start switch is faulty | Change the switch * |
| | Low water level in tank | Restore the water level |
| | Pump filter clogged | Clean the pump filter |
| | Current fails to reach the pump | Check the pump electrical supply * |
| The blade does not cut | Pump failure | Change the pump * |
| | Blade fitted in the opposite direction to that of rotation | Remove the blade and reposition it in the direction shown on the blade label |
| | Worn blade | Change the blade |
| * Operation to be carried out by an electrician | | |

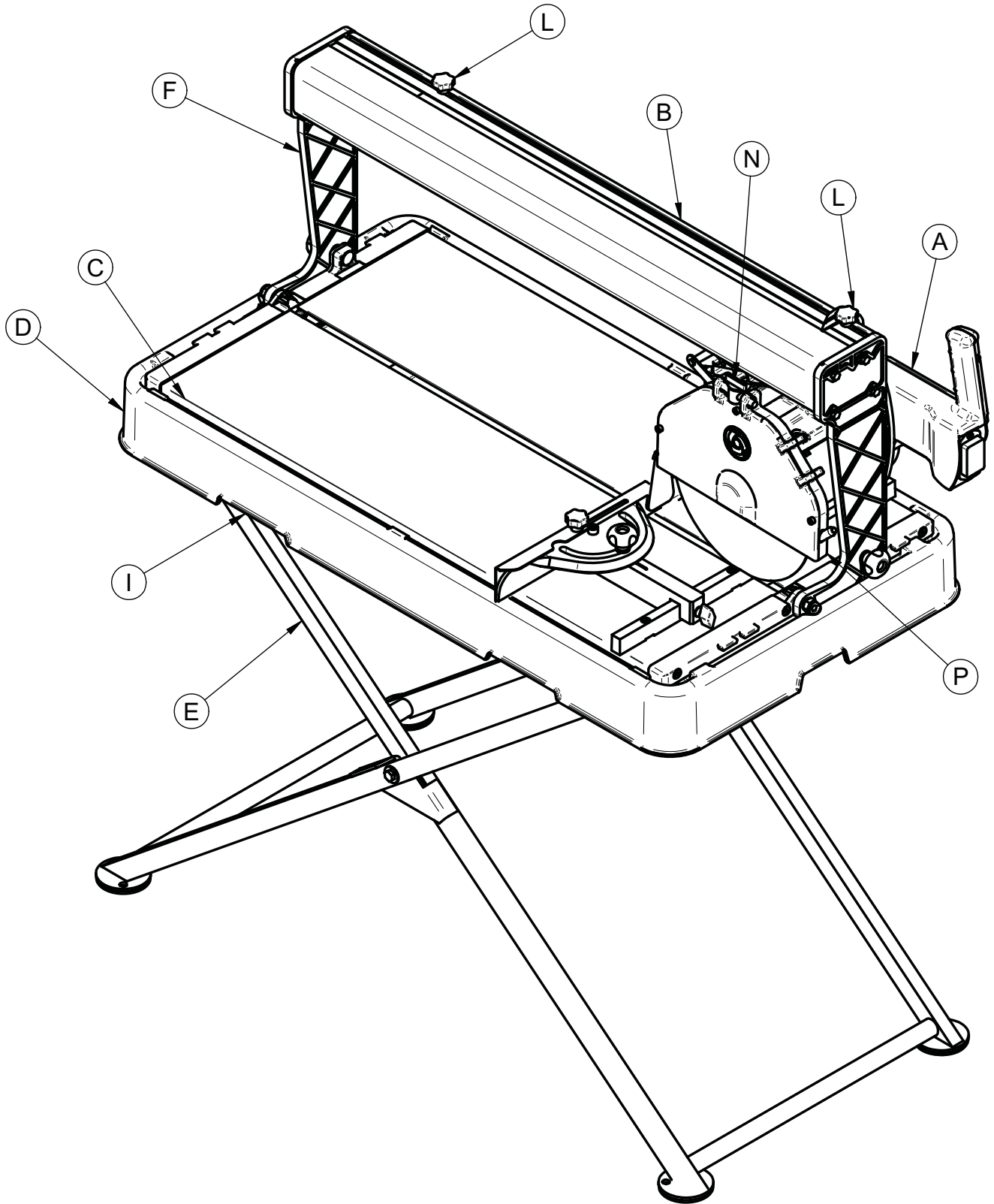

FIG. 1

FIG. 2

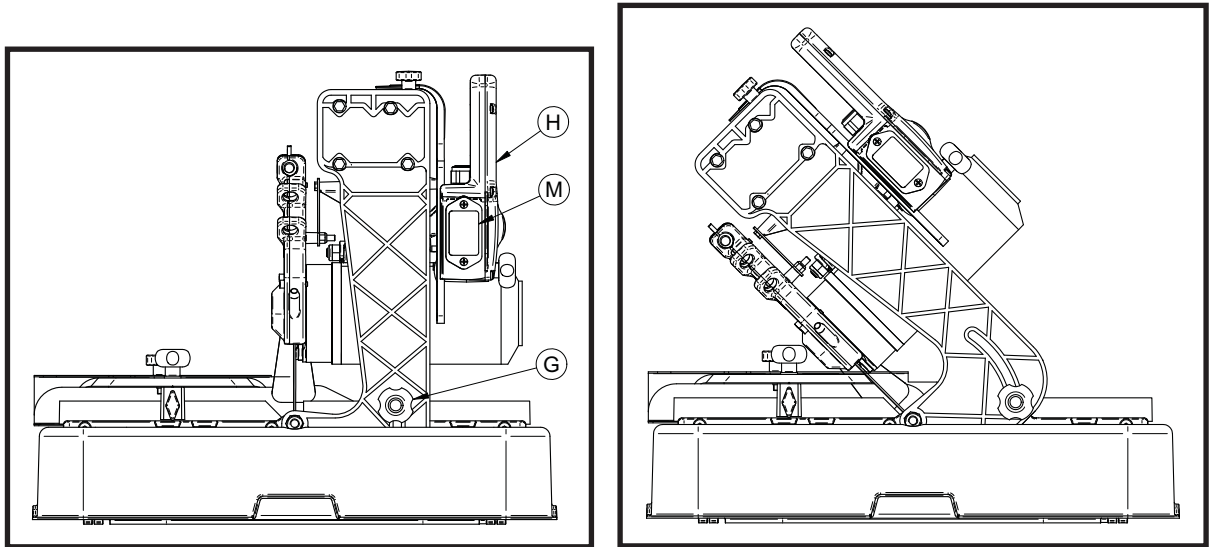

FIG. 3

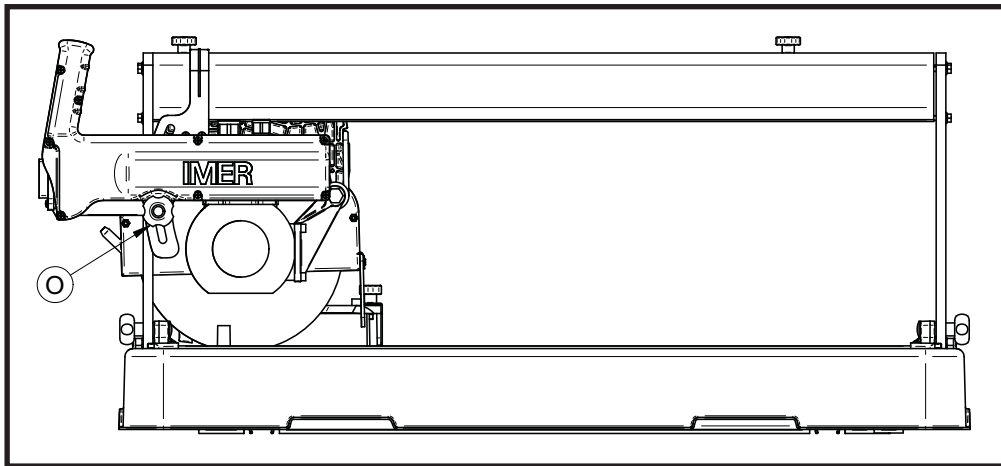
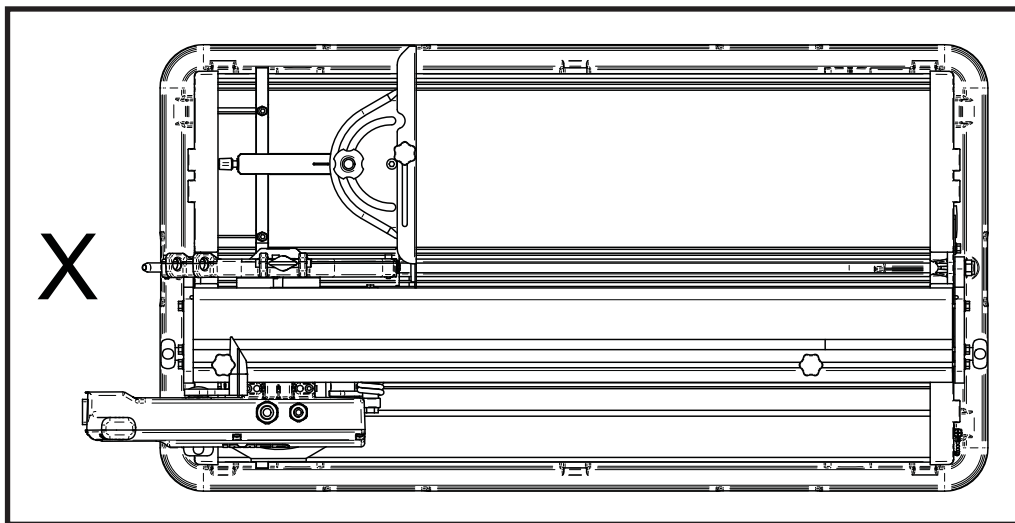
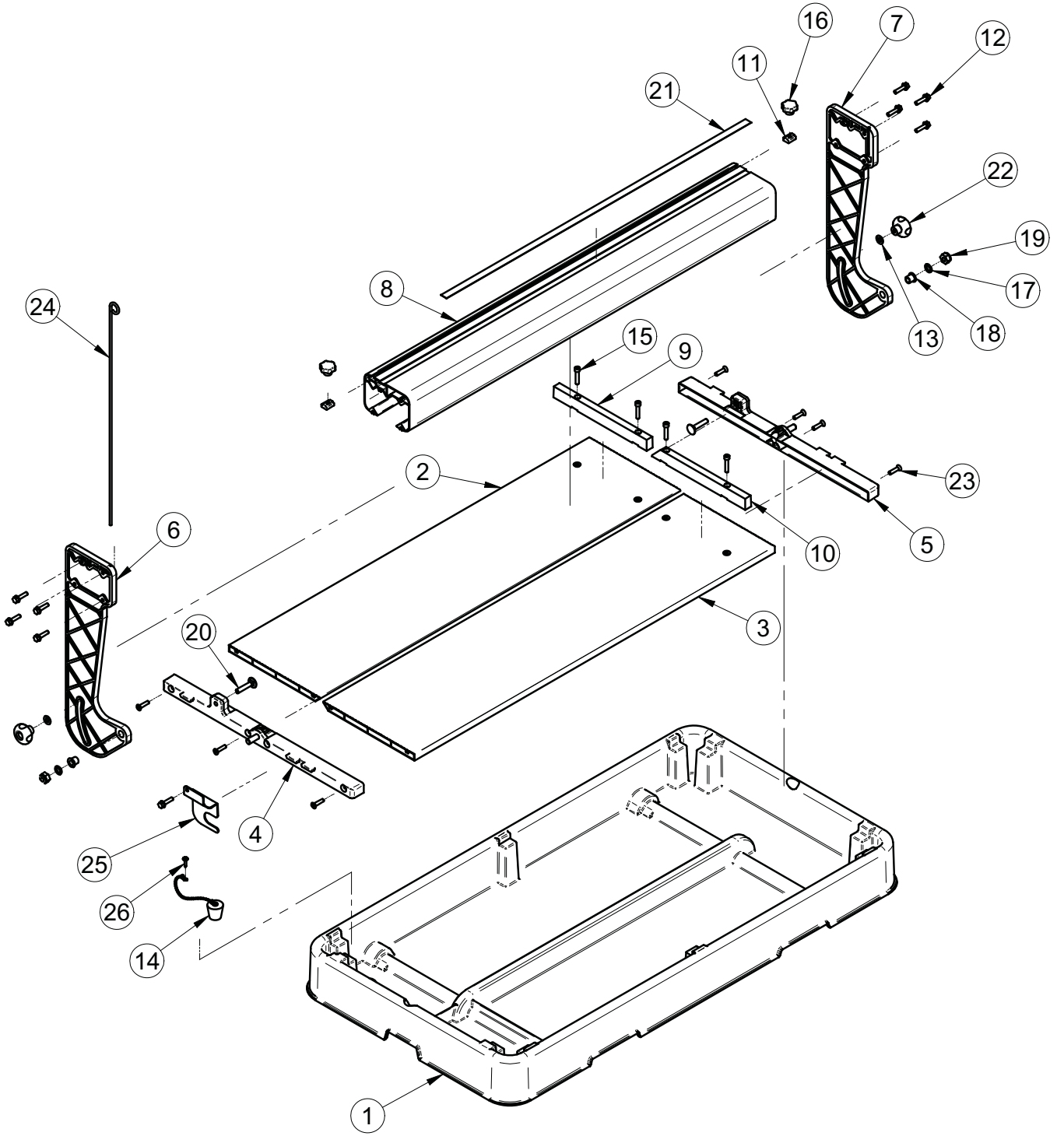

FIG. 4





| TAV. 1 - MACHINE STRUCTURE | | | |
|----------------------------|---------|-------------------|------------------|
| REF. | CODE | DESCRIPTION | NOTES |
| 1 | 3210055 | TANK | |
| 2 | 3226064 | R.H. SURFACE | |
| 3 | 3226265 | L.H. SURFACE | |
| 4 | 3226070 | REAR SIDE | |
| 5 | 3226069 | FRONT SIDE | |
| 6 | 3226359 | REAR ARM | |
| 7 | 3226357 | FRONT ARM | |
| 8 | 3234381 | SLIDEWAY | |
| 9 | 3226073 | RIGHT FENCE | |
| 10 | 3226074 | LEFT FENCE | |
| 11 | 3210071 | T-NUT | |
| 12 | 3210099 | BOLT | TEFR 6X25 |
| 13 | 3210576 | WASHER | D.8,4X17X1,5 |
| 14 | 2235429 | CAP | |
| 15 | 2222545 | BOLT | TCEI 5931 M6X30 |
| 16 | 3204865 | KNOB | M6 |
| 17 | 3226087 | WASHER | D.10,5X17X1,5 |
| 18 | 3226088 | BUSHING | |
| 19 | 2223920 | NUT | 7474 M10 |
| 20 | 3226747 | BOLT | TTDE 5732 8X40 |
| 21 | 3210069 | MILLIMETRED STRIP | |
| 22 | 2284866 | KNOB | M8 |
| 23 | 2222584 | BOLT | TSPEI 5933 M6X25 |
| 24 | 3210070 | ROD | |
| 25 | 3226083 | BRACKET | |
| 26 | 2222449 | BOLT | TC 6954 3.5X19 |

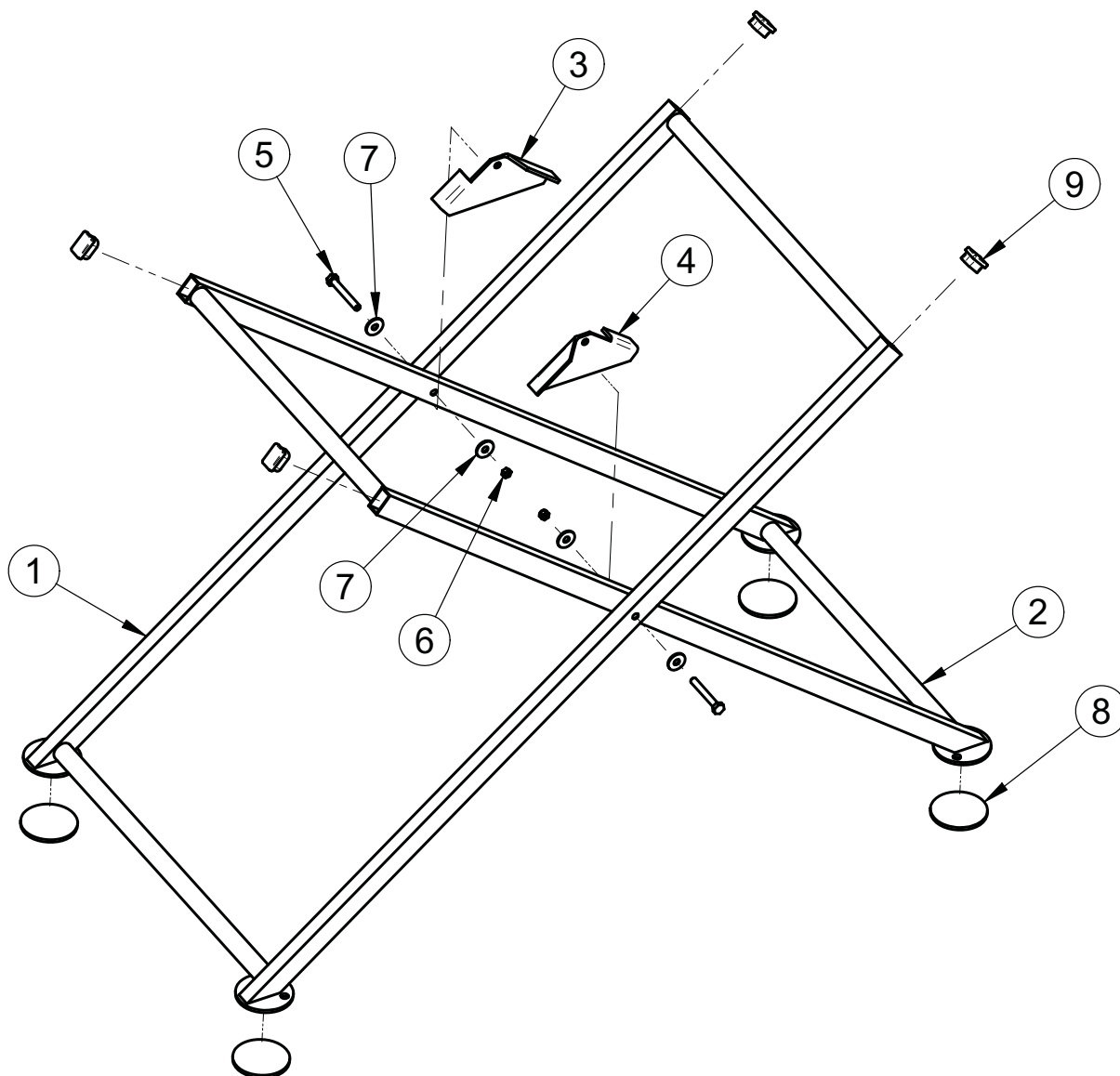
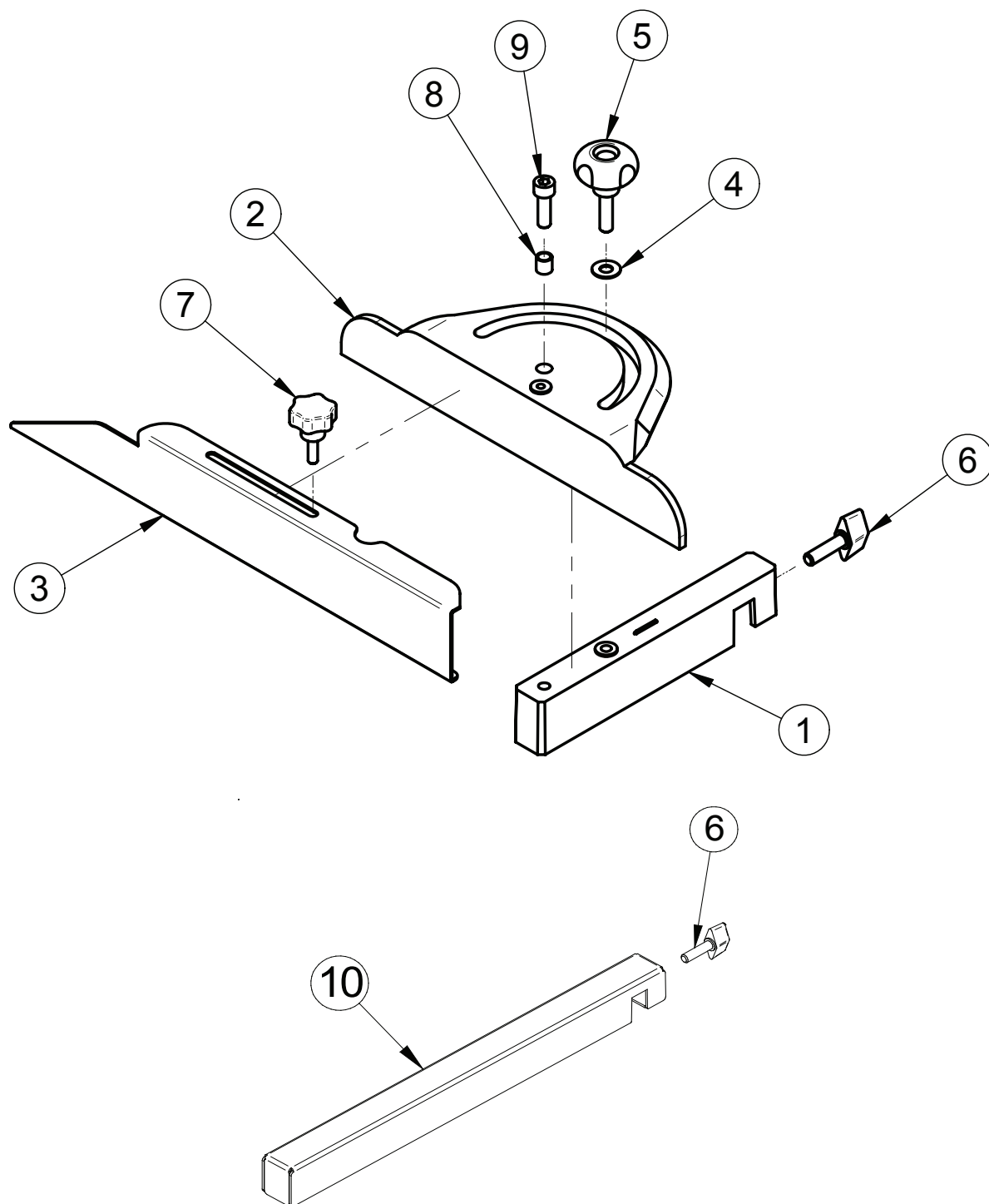
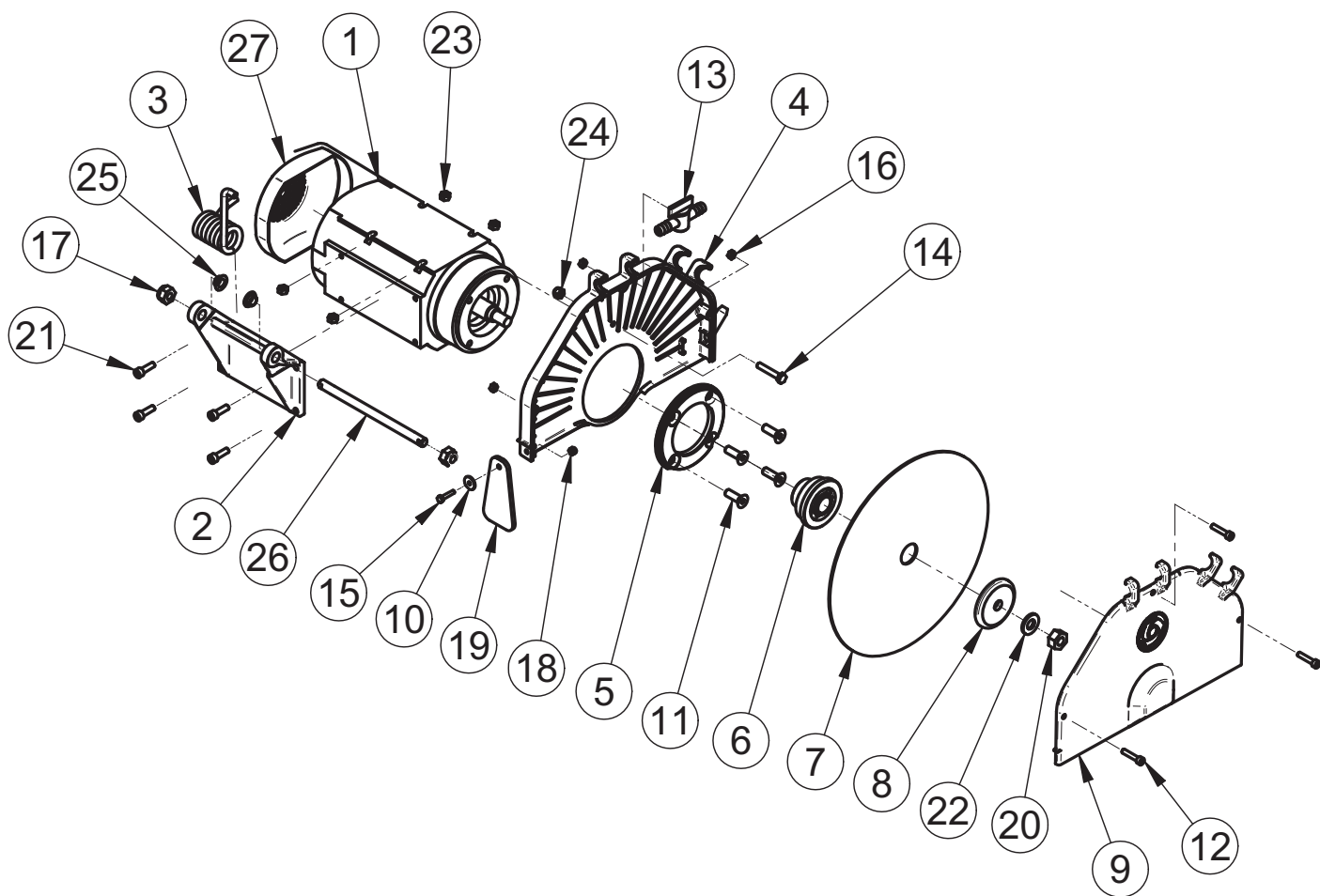

FIG. 6

| TAV. 2 - COMPLETE FRAME | | | |
|-------------------------|---------|--------------------------|---------------------|
| REF. | CODE | DESCRIPTION | NOTES |
| 1 | 3210641 | EXTERNAL TRESTLE ELEMENT | |
| 2 | 3210645 | INTERNAL TRESTLE ELEMENT | |
| 3 | 3207193 | RIGHT RABBET | |
| 4 | 3207194 | LEFT RABBET | |
| 5 | 1222030 | BOLT | TE 8.8 5737 M8X60 Z |
| 6 | 2223923 | NUT | 7473 M8 |
| 7 | 2224204 | WASHER | 6593 D.8X24 Z |
| 8 | 3210646 | RUBBER COATING | |
| 9 | 3206205 | TERMINAL | |



| 3226358 | | TAV. 3 - COMPLETE GONIOMETER | |
|---------|---------|------------------------------|-----------------|
| REF. | CODE | DESCRIPTION | NOTES |
| 1 | 3230617 | GONIOMETER SUPPORT | |
| 2 | 3230616 | GONIOMETER | |
| 3 | 3226360 | SLIDING ROD | |
| 4 | 2224140 | WASHER | 6593 D.8X18 |
| 5 | 3207939 | HANDWHEEL | M8X30 |
| 6 | 3211381 | HANDWHEEL | M8X30 |
| 7 | 3223279 | HANDWHEEL | M6X20 |
| 8 | 3230638 | SPACER | |
| 9 | 2222511 | BOLT | TCEI 5931 M8X25 |
| 10 | 3231271 | BAR | |



| TAV. 4 - BLADE PROTECTION MOTOR ASSEMBLY | | | |
|--|---------|----------------|-------------------|
| REF. | CODE | DESCRIPTION | NOTES |
| 1 | 3230037 | MOTOR | |
| 2 | 3230255 | ENGINE SUPPORT | |
| 3 | 3210087 | SPRING | |
| 4 | 3211935 | BLADE GUARD | |
| 5 | 3210043 | SPACER BRACKET | |
| 6 | 3210238 | INNER FLANGE | |
| 7 | 1193853 | BLADE | |
| 8 | 3210046 | OUTER FLANGE | |
| 9 | 3211933 | BLADE GUARD | |
| 10 | 2224535 | WASHER | |
| 11 | 2222587 | BOLT | TSPEI 5933 M8X20 |
| 12 | 3204399 | BOLT | TCEI 5931 M5X25 |
| 13 | 3207884 | COCK | |
| 14 | 3209060 | BOLT | TE 8.8 5737 M6X35 |
| 15 | 2222001 | BOLT | TE 8.8 5737 M4X20 |
| 16 | 2223352 | NUT | 5588 D.5 |
| 17 | 2223920 | NUT | 7474 M10 |
| 18 | 2223926 | NUT | 7473 M4 |
| 19 | 3210050 | SPRAY SHIELD | |
| 20 | 3210053 | NUT | 5588 M12 Z SX |
| 21 | 2222540 | BOLT | TCEI 5931 M6X20 |
| 22 | 2224380 | WASHER | 6592 D.12X25 |
| 23 | 2223280 | NUT | 5588 M6 |
| 24 | 2223924 | NUT | 7473 M6 |
| 25 | 3230251 | BUSHING | GFM-1012-6 |
| 26 | 3230250 | GOUPILLE | |
| 27 | 3230644 | FAN COVER | |

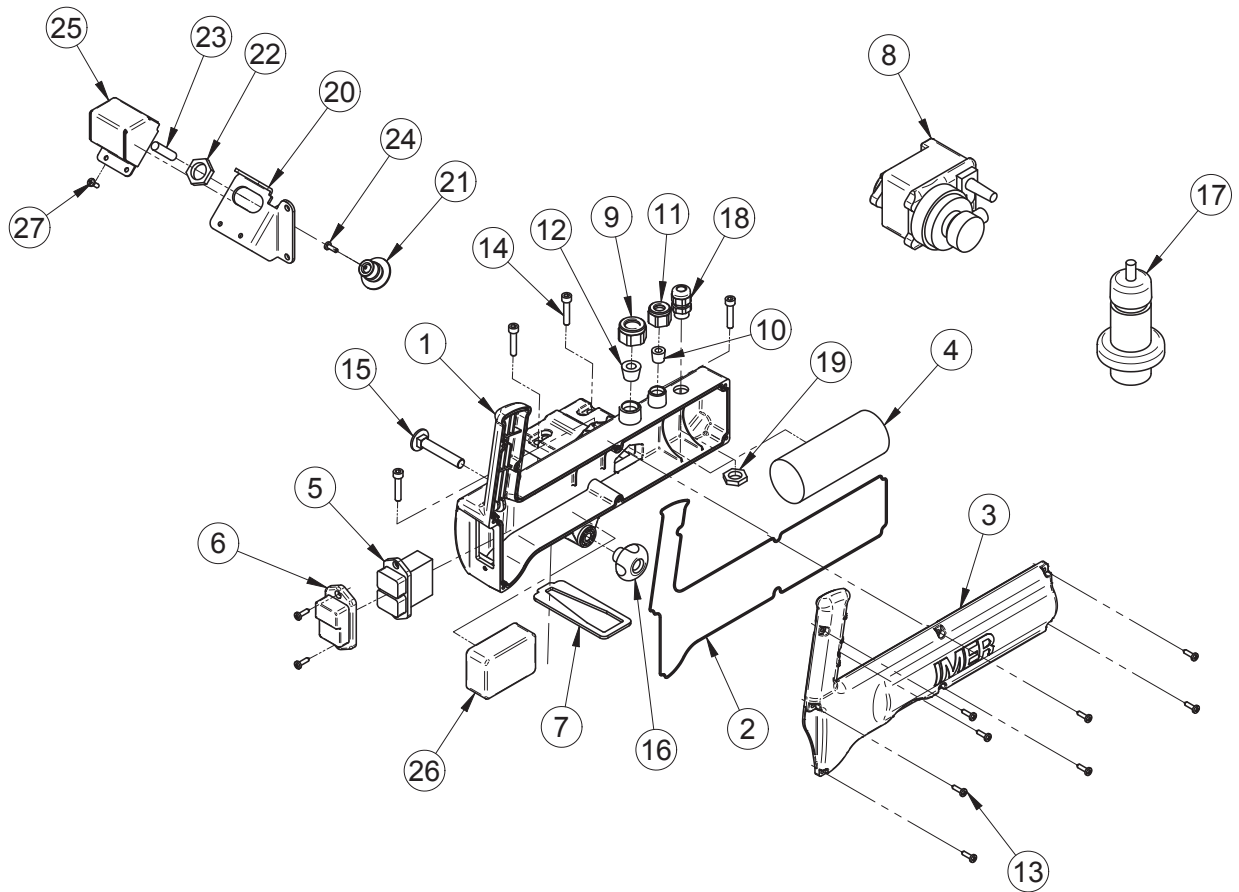

| TAV. 5 - ELECTRIC PANEL | | | |
|-------------------------|---------|--------------------------|--------------------|
| REF. | CODE | DESCRIPTION | NOTES |
| 1 | 3227467 | JUNCTION BOX | |
| 2 | 3210114 | GASKET | |
| 3 | 3210231 | COVER | |
| 4 | 3210232 | CAPACITOR | |
| 5 | 3210233 | SWITCH | |
| 6 | 3209340 | LEAKAGE PROTECTION | |
| 7 | 3225596 | GASKET | |
| 8 | 3233422 | WATER PUMP | |
| 9 | 3226095 | CABLE GLAND LOCKING RING | PG 16 |
| 10 | 3226101 | CABLE GLAND GROMMET | PG 16 |
| 11 | 3226098 | CABLE GLAND LOCKING RING | PG 11 |
| 12 | 3226100 | CABLE GLAND GROMMET | PG 11 |
| 13 | 3210116 | BOLT | TCTC 4,2X16 |
| 14 | 2222540 | BOLT | TCEI 5931 6X20 |
| 15 | 3210096 | BOLT | TTCQ 5732-65 M8X60 |
| 16 | 2284866 | HANDWHEEL | 180-40-M8 |
| 17 | 3224630 | PLUG + ELECTRIC CABLE | |
| 18 | 3227508 | CABLE CLAMP | PG 9 |
| 19 | 3227487 | CABLE GLAND NUT | PG 9 |
| 20 | 3227481 | SUPPORT | |
| 21 | 3227483 | ADJUSTMENT BLOCK | |
| 22 | 3227489 | CABLE GLAND NUT | M20x1.5 |
| 23 | 3228250 | LASER | |
| 24 | 3207155 | BOLT | TC PH 7687 M4X10 |
| 25 | 3227482 | COVER | |
| 26 | 3228251 | POWER SUPPLY | |
| 27 | 2222424 | BOLT | TC PH 6954 4.2X9.5 |

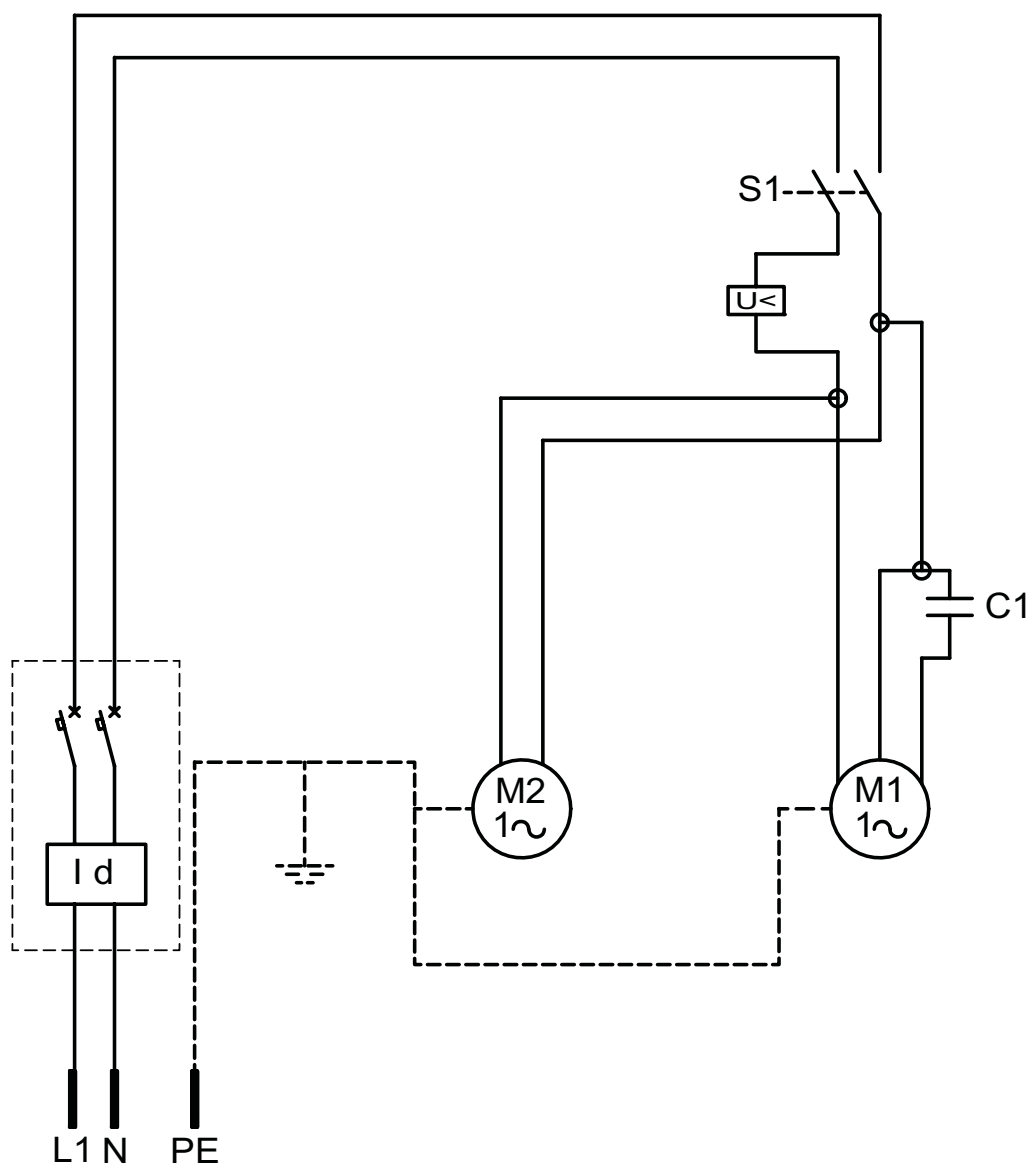

| WIRING DIAGRAM | |
|----------------|-------------------------|
| REF. | DESCRIPTION |
| S1 | CONTROL SWITCH |
| C1 | CAPACITOR |
| PE | EARTHING CABLE |
| N | NEUTRAL LINE CABLE |
| L1 | PHASE LINE CONDUCTOR |
| M1 | BLADE MOTOR |
| M2 | PUMP MOTOR |
| ID | CURRENT CIRCUIT BREAKER |

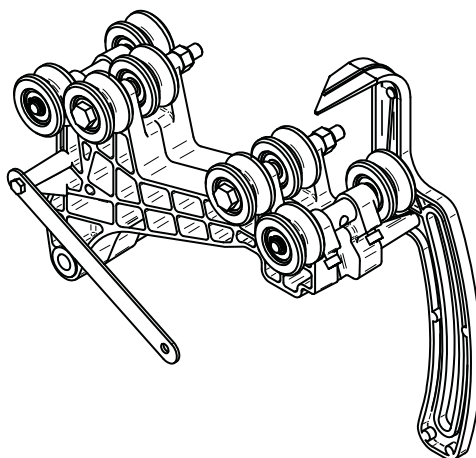
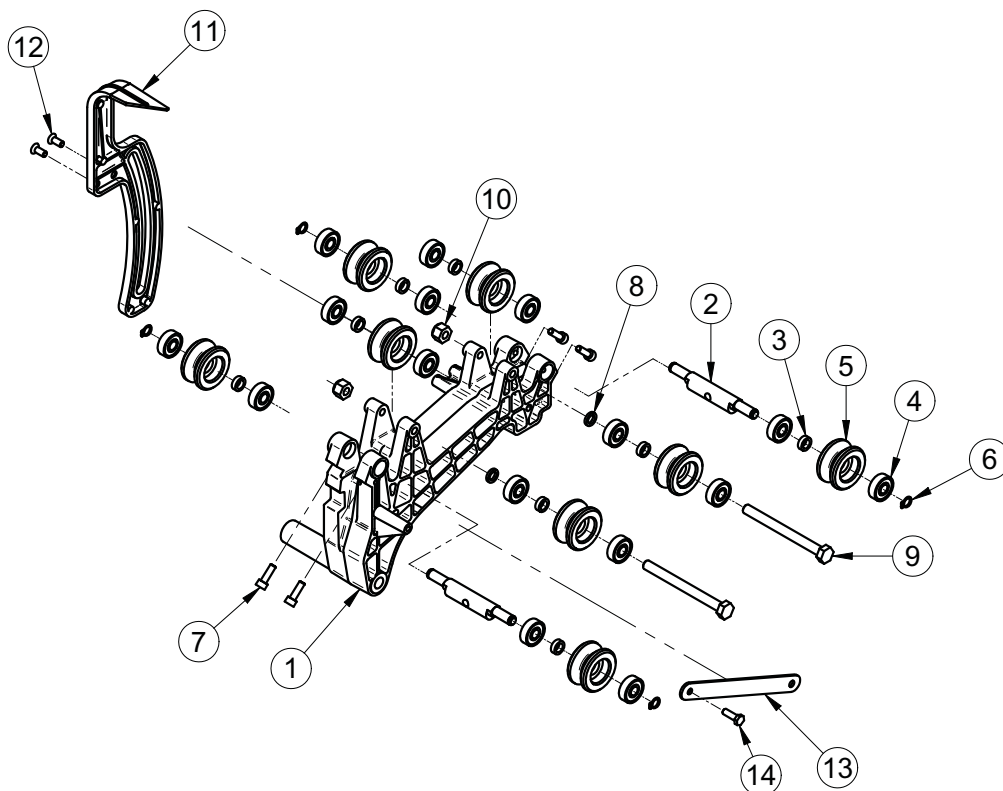

| TAV. 6 - CARRIAGE | | | |
|-------------------|---------|----------------|-----------------|
| REF. | CODE | DESCRIPTION | NOTES |
| 1 | 3210031 | CARRIAGE | |
| 2 | 3210032 | CAM | |
| 3 | 3207393 | SPACER BRACKET | |
| 4 | 3204945 | BEARING | 608 2RS1 |
| 5 | 3207397 | WHEEL ASSEMBLY | |
| 6 | 3210627 | RING | |
| 7 | 3210036 | BOLT | TCEI 5931 M5X16 |
| 8 | 3210622 | SPACER BRACKET | |
| 9 | 2222114 | BOLT | TE 5737 M8X90 |
| 10 | 2223923 | NUT | 7473 M8 |
| 11 | 3210028 | CARRIAGE BLOCK | |
| 12 | 3210105 | BOLT | TSP PH M5X12 |
| 13 | 3210029 | BLADE GUARD | |
| 14 | 2222000 | BOLT | TE 5739 M5X16 |

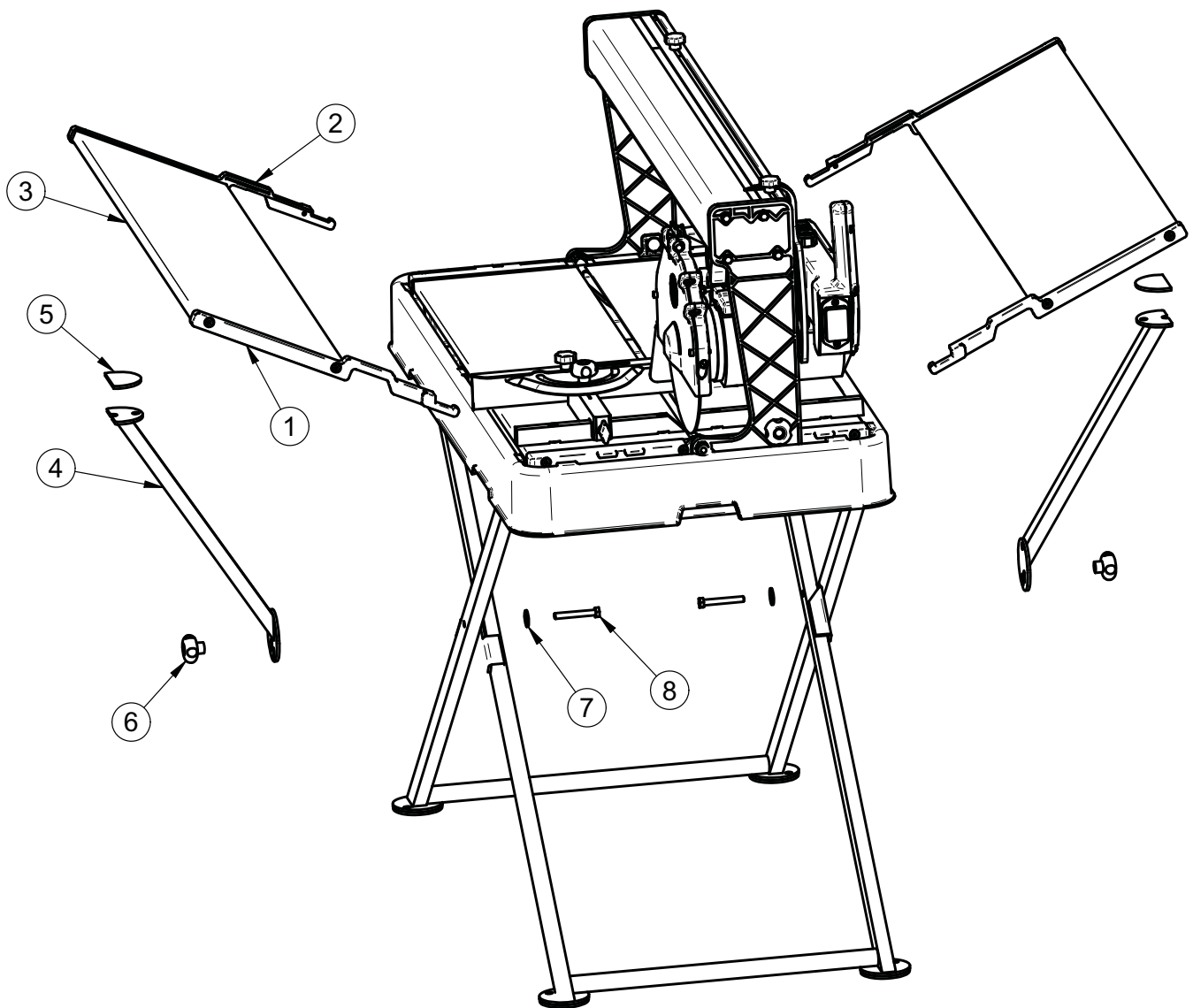

FIG. 7

| COD.1188166 | | TAV. 7 - SIDE ROLLER | |
|-------------|---------|----------------------|---------------------|
| REF. | CODE | DESCRIPTION | NOTES |
| 1 | 3226145 | SUPPORT | |
| 2 | 3226146 | SUPPORT | |
| 3 | 3226066 | SIDE ROLLER | |
| 4 | 3226233 | SUPPORT | |
| 5 | 3210646 | RUBBER COATING | |
| 6 | 2284866 | HANDWHEEL | M8X30 |
| 7 | 2224204 | WASHER | 6593 D.8X24 Z |
| 8 | 1222030 | BOLT | TE 8.8 5737 M8X60 Z |

ONE YEAR WARRANTY

We warrant to the original purchaser that the IMER equipment described herein (the "equipment") shall be free from defects in material and workmanship under normal use and service for which it was intended for a period of one (1) year from the date of purchase by the original purchaser.

Our obligation under this warranty is expressly limited to replacing or repairing, free of charge, F.O.B. our designated service facility, such part or parts of the equipment as our inspection shall disclose to be defective. Parts such as engines, motors, pumps, valves, electric motors, etc. furnished by us but not manufactured by us will carry only the warranty of the manufacturer. Transportation charges or duties shall be borne by the purchaser. This shall be the limit of our liability with respect to the quality of the equipment.

This warranty shall not apply to any equipment, or parts thereof, which has been damaged by reason of accident, negligence, unreasonable use, faulty repairs, or which has not been maintained and operated in accordance with our printed instructions for our equipment. Further, this warranty is void if the equipment, or any of its components, is altered or modified in any way.

THIS WARRANTY IS EXPRESSLY IN LIEU OF ALL OTHER WARRANTIES, EXPRESSED OR IMPLIED, INCLUDING ANY IMPLIED WARRANTY OF MERCHANTABILITY OF FITNESS FOR A PARTICULAR PURPOSE.

We make no other warranty, representation or guarantee, nor is anyone authorized to make one on our behalf. We shall not be liable for any consequential damage of any kind, including loss or damage resulting, directly or indirectly, from the use or loss of use of the machine. Without limiting the generality of the foregoing, this exclusion from liability embraces the purchase's expenses for downtime, damages for which the purchaser may be liable to other persons, damages to property, and injury or death of any persons.

This warranty shall not be deemed to cover maintenance parts, including but not limited to blades, belts, hoses, hydraulic oil or filters, for which we shall have no responsibility or liability whatsoever.

IMER U.S.A. Inc.
221 Westhampton Place
Capitol Heights, MD 20743
Ph. 301.336.3700
Fax 301.336.6687
Toll Free: 800.275.5463
www.imerusa.com
info@imerusa.com