



MIXERS

SAWS

DUMPERS

2023 EQUIPMENT CATALOG





TOLL FREE: **800.275.5463**
WWW.IMERUSA.COM



IMER USA, Inc.
423 Bank Street, Suite 180
Southlake, TX 76092
Tel. (800) 275-5463 - Fax (301) 336-6687
www.imerusa.com

Due to our ongoing Research and Development efforts these products and their specifications are subject to change without notice.

The California Office of Environmental Health Hazard Assessment Requires this Specific Warning: Cancer and Reproductive Harm - www.p65warnings.ca.gov

TABLE OF CONTENTS



MIXERS

BARREL MULTI-MIXERS.....	4
Wheelman II.....	6
Minuteman II.....	7
Multi-Mix 350.....	8
Workman II 250 & 350.....	9

SPIN SERIES MIXERS.....	10
Spin 15 A.....	10
Spin 30 Plus.....	11

VERTICAL SHAFT MIXERS.....	12
Mix-All 60.....	12
Mix 120 Plus.....	13
Mix 360.....	14
Mix 750.....	15

SAWS

COMBICUT SERIES.....	34
Combicut 200 VA & 250 VA36	
Combicut 250 / 1000 & 150038	
Combicut 350 iPower.....	39

MASONRY SERIES.....	40
Masonry 350 Smart.....	40
Masonry 750 Plus.....	41

SAW BLADES

IMER SAW BLADES.....	42
----------------------	----

EARTH MOVING

CARRY MINI-DUMPERS.....	44
Carry 105.....	46
Carry 105 Electric.....	47
Carry 107.....	48
Carry 107HT Hi-Tip Kit.....	49
Carry 108HF.....	50
Carry 150.....	51
Carry 230.....	52

SPECIALTY PRODUCTS

EZEE CLEAN.....	53
-----------------	----



MIXERS SERIES



MORTAR, STUCCO, GROUT, CONCRETE MIXERS

Multi-Mixers Continuous Mixers Vertical Shaft Mixers

IMER is known world-wide for its mixers due to its vast experience from small, portable mixers to its large batch plants. No matter how large or small the project may be, IMER has a solution to help you maximize your time and ROI. Designed to handle the most impossible of mix designs and aggregate types.

The IMER Multi-Mixers, Spin Series Continuous Mixers, and Vertical Shaft mixers are ideal for efficiently and quickly mixing all types of pre-blended materials from dry pack consistency to a fluid grout. Mortar one day, stucco the next. Tackle high-strength grouts the day after, or make them all in one day without any waste.

In addition, IMER Mixers are designed to work with IMER mixer/pump spray machines and grout pumps - the perfect companions for semi-automatic production.





WHEELMAN II

COMPACT, PORTABLE MULTI-MIXER



- WHEELMAN II | Model # 1105421 | 110V/60Hz 0.5 HP | Poly Drum
- WHEELMAN II | Model # 1105422 | 110V/60Hz 0.5 HP | Steel Drum (New 2021)
- WHEELMAN II GAS | Model # 1105426 | 3 HP, Honda Engine | Poly Drum

LIGHTWEIGHT AND PORTABLE MIXER FOR MORTAR, STUCCO, GROUT, OR CONCRETE

The Wheelman II wheelbarrow-style mixer is built to tackle all types of projects and materials, such as mortar, stucco, grout, concrete, and is the only mixer with a removable drum that can be loaded by one person into a small vehicle. Use it to mix, transport, and then dump right to your work area. The Polyethylene drum is spun-injected, a plastic forming process that delivers a perfectly round and extra-durable drum. The optional 355° Swivel Stand is an excellent add-on for an easy to dump solution. Available with a Honda gas engine or an industrial-grade electric 110V motor. Choose a poly drum or the new metal drum model!



SPEED

Mix mortar, stucco, grout, or concrete in less than 4 minutes.

GAS POWER

Working on a jobsite without electrical power, no problem, the Wheelman is available with a 3 hp Honda engine.

POWER

The fully enclosed 1/2 hp 110V industrial grade motor with direct gear drive provides non-stop performance on any construction project. These mixers truly are contractor duty.

OPTIONAL 355° SWIVEL STAND

Wheelman stand is easy to dump, and it swivels a full 355°. Item # 1105490



Technical specifications

POWERED by **HONDA**

	WHEELMAN II Gas	WHEELMAN II Electric
Drum capacity	5 cu ft	5 cu ft
Batch output	2.5 cu ft	2.5 cu ft
Motor rating	1/2 hp 110v/6amp	n/a
Gas engine*	n/a	Honda 3 hp
Drum diameter	24 in	24 in
Discharge outlet height	8 in / 21 in w/stand	8 in / 21 in w/stand
Wheel size	14 in pneumatic tires	14 in pneumatic tires
Weight	gas 115 lbs	elec. 101 lbs
Width**	26 (26) in	26 (26) in
Length**	46 (29) in	46 (29) in
Height**	36 (27-1/2) in	36 (27-1/2) in

(*) Warning, Cancer and Reproductive Harm - <https://www.p65warnings.ca.gov>
 (**) Operating Dimensions (palletized)

MINUTEMAN II

PORTABLE MULTI-MIXER

MINUTEMAN II | Model # 1126608 | 110V/60Hz 0.5 HP | Steel Drum
 MINUTEMAN II | Model # 1126632 | 110V/60Hz 0.5 HP | Poly Drum



BELTLESS GEAR-DRIVEN PORTABLE ELECTRIC MIXER

The Minuteman II is the highest performing, most reliable, affordable small portable mixer today. It is easy to assemble and transport plus the electric motor runs quietly making it perfect for indoor applications. The oil bath gearbox never needs maintenance like some other brands on the market. The Minuteman II has been used for the past 30+ years to mix mud to lay block, stucco houses, build patios, mix concrete pads, and more. Choose a metal or poly drum.



Technical specifications

MINUTEMAN II Electric	
Drum capacity	5 cu ft
Batch output	3 cu ft
Motor rating	1/2 hp 110v/6amp
Gas engine	n/a
Drum diameter	24 in
Discharge outlet height	21 in
Wheel size	10 in tires
Weight*	120 lbs
Width*	28 (26) in
Length*	52 (26) in
Height*	57 (27) in

(* Operating Dimensions (palletized))



PORTABILITY

In just one minute, the Minuteman or Wheelman can be "knocked down" into easy-to-load components. All this by one person, with no tools required.

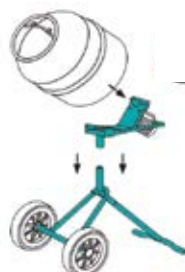

MULTI-MIX 350 SYNTESI

PORTABLE MULTI-MIXER



MULTI-MIX 350 | Model # 1105802 | 110V/60Hz 1.9 HP

THE MULTI-MIX 350 IS IMER'S NEW PORTABLE, NON-TOWABLE MIXER. MORTAR, STUCCO, GROUT, OR CONCRETE - BIG BROTHER TO THE WHEELMAN II AND MINUTEMAN II MIXERS

Designed and built to mix large batches in a portable 110V traditional concrete mixer. The transmission system inserted in the arm and the convenient worm screw tilting system makes it



Steady, quiet electric motor

"Posi-lock" stops the drum from dumping

Oil bath gearbox drive

Easy mobility slide out transport

Aggressive paddles to mix fast and complete

Domes inside the drum eject the material back into the paddles

Box steel frame is very strong and reliable

Forklift pockets for easy movement



PERFORMANCE MIXING BLADES

The Multi-Mix 350 blades are heavy-duty construction, welded and screwed for added strength and a consistent mix.



QUIET GEARBOX

Direct drive gearbox to the drum, no more external drive gears. This drive system is whisper quiet and is sealed for life. No maintenance is required.

Technical specifications

MULTI-MIX 350	
Drum capacity	12 cu ft
Batch output	9.5 cu ft
Drum diameter	34-¾ in
Wheel size	15 in
Electric motor power rate	1.9 hp 110v
Weight*	385 lbs
Width*	32-½ in
Length*	63-¼ in
Height*	63 in

(* Operating Dimensions (palletized))



WORKMAN II 250 & 350

TOWABLE MULTI-MIXER

WORKMAN II 250 GAS	Model # 1105850	5.5 HP Honda GX
WORKMAN II 250 E	Model # 1105842	110V/60Hz 1.5 HP, Single-Phase
WORKMAN II 250 E	Model # 1105843	220V/60Hz 1.5 HP, Single-Phase
WORKMAN II 350 GAS	Model # 1105855	5.5 HP Honda GX
WORKMAN II 350 E	Model # 1105862	110V/60Hz 1.5 HP, Single-Phase
WORKMAN II 350 E	Model # 1105863	220V/60Hz 1.5 HP, Single-Phase



Models Without Motors
1105851 - Workman II 250
1105856 - Workman II 350

MIX PERFECT MORTAR AND CONCRETE

The Workman II 250 and 350 Multi-mixers are the contractor's choice for heavy-duty mixers. IMER's steel drum towable mixers are easy to use, easy to maintain, durable, reliable, and long-lasting. Available in a full range of sizes and engine and motor configurations.

50 lb bag capacity:
15 bags - Workman 250,
25 bags - Workman 350

"Posi-lock" stops
the drum from
dumping

Box steel frame
is very strong
and reliable

Drop the 4 legs
for stability

Impact-resistant
fenders keep
their shape

Mix mortar, stucco,
grout, and concrete

Torsion bar
suspension for a
smooth ride

Comes complete
with spare tire

Technical specifications

POWERED by
HONDA

	WORKMAN II 250	WORKMAN II 350
Drum capacity	9 cu ft	12 cu ft
Batch output	6 cu ft	9.5 cu ft
Drum diameter	29-½ in	34-¾ in
Discharge outlet height	27-¾ in	26-½ in
Pneumatic wheels	20 in	20 in
Gas engine*	5.5 hp Honda	5.5 hp Honda
Electric motor rating	1.5 hp 110/220v	1.5 hp 110/220v
Weight	525 lbs	650 lbs
Width**	50 (50) in	50 (50) in
Length**	72 (80) in	76-½ (86) in
Height**	55 (68) in	56 (72) in

(*) Warning: Cancer and Reproductive Harm - <https://www.p65warnings.ca.gov>
(**) Operating Dimensions (palletized)



POWER OPTIONS

A variety of industrial duty options -- Honda gas engines and electric motors are available too.



"POSI-LOCK" SAFETY FEATURE

When you stop rotating the dump wheel it locks in place, automatically.



QUIET GEARBOX

A direct drive gearbox to the drum means no more external drive gears. The drive system is whisper quiet and is sealed for life. No maintenance required.



WHY PAY EXTRA FOR A HITCH?

Every Workman II mixer comes with a commercial-duty tow hitch.

SPIN 15A

CONTINUOUS MIXER FOR PREMIXED MATERIALS



SPIN 15A | Model # 1106340 | 110V/60Hz, 1.75 HP

INDUSTRY CHANGING, HIGH-OUTPUT CONTINUOUS MIXERS

Ideal for quickly and efficiently mixing; preblended plasters, mortars, stuccos, grouts, self-leveling underlayment, preblended conventional floor-screeds. Team the continuous mixer with an IMER spray and grout pump for semi-automatic production.

Maintenance-free patented parallel axis gearbox

High-torque motor for optimal start-up under full load

New patented iDUST® grate included

250 lb. hopper capacity

Stainless steel water pump is optional

3 adjustable height positions

Patented IMER mixer coupling for easy cleanup and disassembly

Mix up to three, 80 lb. bag of pre-mix in 3 minutes



DUST GRATE INCLUDED

The Spin 15 & Spin 30 Plus include an iDUST® dust grate attachment. The dust grate attachment utilizes multiple vents and connects to a dry vacuum to pull dust downward.

OPTIONAL WATER PUMP

Optional water kit for spin 15. Use the pump to feed water from a tank or when the water supply is inadequate.
Item# 1107638 - Spin 15A Water Pump Kit



Technical specifications

	SPIN 15A
Hopper/tank capacity	2.12 cu ft
Mixing performance	.5 cu ft /min
Mixer/paddle speed	280 rpm
Motor power rate	1.75 hp
Standard water pump	optional
Standard dust grate	yes
Weight (with packing)	187 lbs (196)
Dimensions	27-½ W x 54 L x 46 H in
Box dimensions	31-½ W x 23-¼ L x 32-½ H in

SPIN 30 PLUS

CONTINUOUS MIXER FOR PREMIXED MATERIALS

SPIN 30 PLUS | Model # 1106152 | 220V/60Hz, 3 HP, Single-Phase

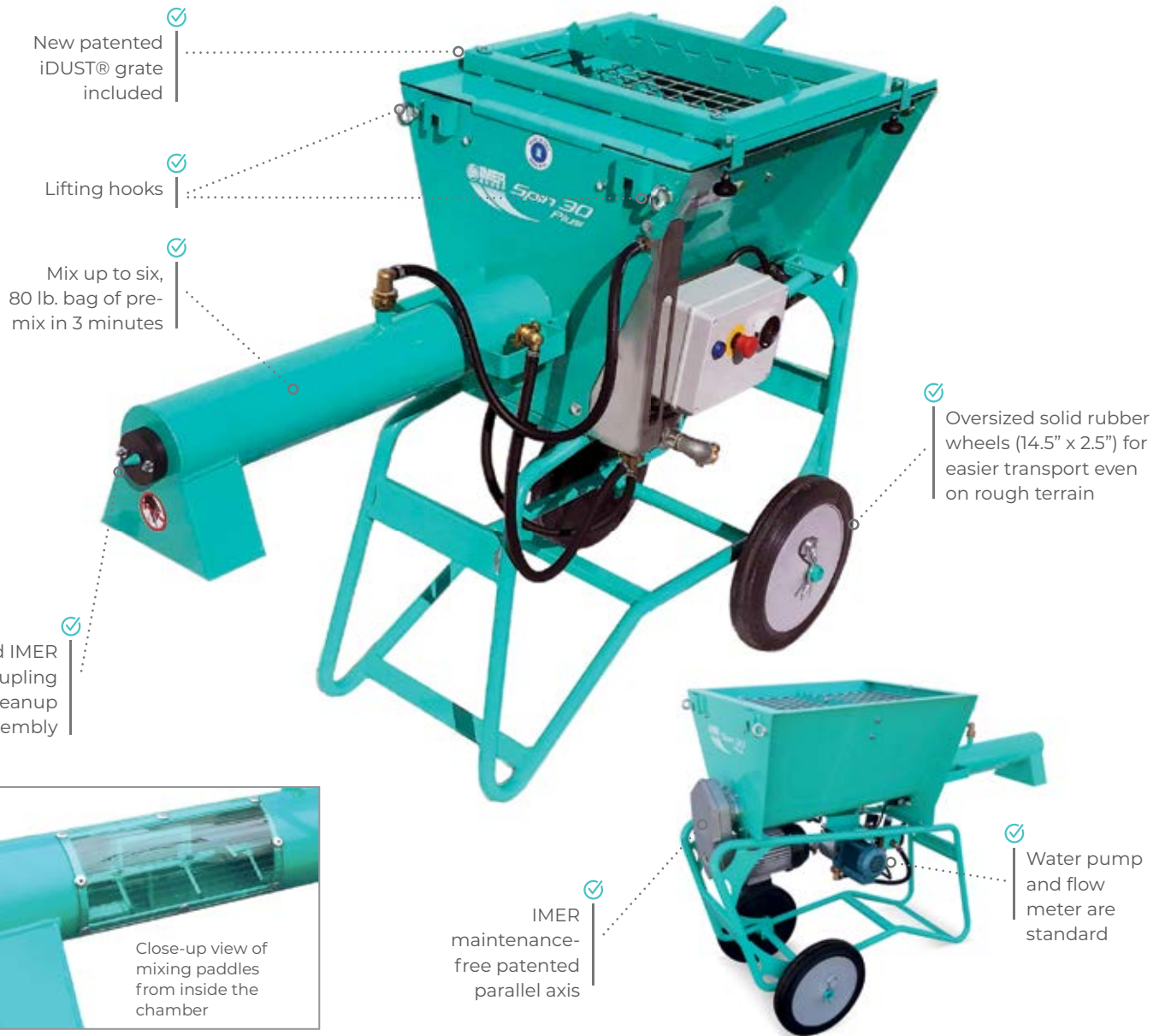

Technical specifications

SPIN 30 PLUS	
Hopper/tank capacity	500 lbs
Mixing performance	1 cu ft /min
Mixer/paddle speed	280 rpm
Motor power rate	3 hp (220v single-phase)
Standard water pump	yes
Standard dust grate	yes
Weight (with packing)	281 lbs (292)

SPIN 15 & SPIN 30 SAFETY

Safety sensor disables mixer if the mixing chamber is opened.



WATER FLOW METER

Allows the water level to be set for easy setup when using the same material.



MIX-ALL 60

PORTABLE PADDLE MIXER



MIX-ALL 60 | Model # 1193988 | 110V/60Hz, 0.75 HP

THE LIGHTWEIGHT, QUIET, PORTABLE YET POWERFUL MIX-ALL 60 SAVES TIME AND REDUCES LABOR COSTS

The 110V motor gearbox drivetrain is both powerful, and quiet. The unique paddles allow it to quickly and thoroughly mix mortar, stucco, thin set, dry pack mortar, epoxy, plaster, and more. It's also used for mixing rubber materials.



Easy to transport, rolls along like a piece of luggage

3/4 HP, 110V motor

High-torque gearbox drive

Comes with 2 12 gal. buckets

5 Pack of Buckets Item# 1193968-K



PADDLES

The Mix-All 60 includes a paddle specifically engineered for mixing mortar, stucco, and grout. Additional paddle attachments are available as an accessory on the new Mix-All or previous models.

LABOR SAVINGS

The Mix-All 60 batches material automatically, freeing the operator for other duties. Handheld drill motors require the full attention of the operator.



POWER

The fully enclosed 3/4 hp 110V industrial grade motor with direct gear drive provides non-stop performance on any construction project. The Mix-All 60 mixer truly is contractor duty.

MINIMAL JOBSITE CLEAN UP

The Mix-All 60 makes batch after batch without slinging or splashing material onto the floor or wall. Easy to use. Easy to clean

Technical specifications

MIX-ALL 60	
Drum capacity	14 gal
Batch output	12 gal / 50 lb bag
Drum diameter	24 in
Maximum aggregate size	3/8 in
Paddle speed	55 rpm
Motor rating	3/4 hp, 110v
Current draw	10 amps
Noise	70 dB(A)
Machine weight (boxed)	66 lbs (70 lbs)
Width*	23 (23) in
Length*	25 (24-1/2) in
Height*	31-3/4 (18) in

(*) Operating Dimensions (boxed)

MIX 120 PLUS MORTARMAN

PORTABLE VERTICAL SHAFT PADDLE MIXER

MIX 120 PLUS | Model # 1194302 | 110V/60Hz, 2 HP, Single-Phase, iDUST® Grate
 MIX 120 PLUS | Model # 1194304 | 110V/60Hz, 2 HP, Single-Phase, Open Grate



✓
 Loading wheels help to place the mixer in the pickup for transportation

✓
 2 HP, 110V motor with gearbox drive with reverse

✓
 Transport wheels to help maneuver the mixer where you need it



VERTICAL SHAFT MIXER WITH A POWERFUL MIXING ACTION

The Mix 120 Plus can make a wheelbarrow of mortar, stucco, grout, or dry pack cement every 3 minutes. Vertical shaft mixers deliver so much mixing torque that the Mix 120 Plus can out produce a two-bag towable mixer when making dry pack cement. Team the continuous mixer with an IMER spray and grout pump for semi-automatic production.



DUST GRATE INCLUDED

The Mix 120+ includes the iDUST® Dust grate attachment. The iDUST® attachment fits on top of the 120+ and connects to a HEPA dry vacuum to safely pull dust downward.



OPEN GRATE OR iDUST® GRATE

When ordering, choose from the iDUST® grate or the open grate. Open grate shown here.



Technical specifications

	MIX 120 PLUS
Drum capacity	4.25 cu ft
Batch output	3 cu ft
Drum diameter	30 in
Maximum aggregate size	3/8 in
Paddle speed	38 rpm
Motor rating	2 hp, 110v
Current draw	15 amps
Noise	70 dB(A)
Machine weight (crated)	286 lbs (310 lbs)
Width*	30 (31) in
Length*	33 (35) in
Height*	50 (38) in

(* Operating Dimensions (crated))



OUTLET

Discharge of material is very controlled. Whether you need a trowel, a bucket, or a wheelbarrow full of material, it's all there with a twist of your arm. Viewing the MIX 120 discharge as seen from below.

MIX ANYWHERE

The 120 Plus passes through standard doorways, gates, and more. The mixing action is neat and controlled, so the mud stays in the drum, and the mixed discharge is equally clean. Mix indoors without the mess or added clean-up.

WHY VERTICAL SHAFT MIXERS?

The paddles are always in the mix, thoroughly and quickly mixing materials without air entrapment. Shown here with rubber paddles (item # 1107618).

REVERSE IT

If the material being mixed starts to clump up or separate, no problem, just hit reverse for a few seconds, then back to forward. The ability to switch from forward to reverse ensures that all types of materials mix well and production keeps moving.

MIX 360 MORTARMAN

TOWABLE VERTICAL SHAFT PADDLE MIXER



Model Without Motors
1194585 - Mix 360 Plus

MIX 360		Model # 1194574		220V/60Hz, 5 HP, Single-Phase
MIX 360		Model # 1194575		220V/60Hz, 5 HP, 3 Phase
MIX 360		Model # 1194576		440V/60Hz, 5 HP, 3 Phase
MIX 360 GAS		Model # 1194578		11 HP Honda GX

THE MIX 360 OFFERS UNPARALLELED PRODUCTION AND JOBSITE / PLANT SAFETY

Vertical shaft mixers use the principles of concrete batch plant design, which allows for the paddles to rotate through the mix rather than lift and drop it as conventional mortar mixers do. The Mix 360 vertical shaft towable mixer easily mixes very low slump materials like dry pack mortar and refractory cement, as well as UHPC.



OPTIONAL DUST GRATE

Take control of dust. Easily attach IMER's iDUST® dust grates to the Mix 360 and attach a vacuum. Watch the dust be pulled downward, away from operators (Item# 1107494)



ACCESSORIES FOR SAFETY

The standard open grate is ideal for materials such as fireproofing.

RELIABILITY

The paddle systems are powered by monster gearboxes which were developed in our batch plant division.

Mixing loads with 3/8 in aggregates is no problem.



PRODUCTION

Listening, studying, and testing have lead to drum and paddle design changes that vastly improve batch output.

Why not have Mini Batch Plant (MBP) production for the cost of a mortar mixer?



INDUSTRIAL ELECTRIC MOTOR

The motors used in the MIX 360 and 750 are industrial-duty electric motors available in a wide range of voltage, single-phase or three-phase. The motors can operate continuously and easily mix stiff, dry materials.



MIX 750 MORTARMAN

TOWABLE VERTICAL SHAFT PADDLE MIXER

- MIX 750 | Model # 1194644 | 220V/60Hz, 5 HP, Single-Phase
- MIX 750 | Model # 1194645 | 220V/60Hz, 7.5 HP, 3 Phase
- MIX 750 | Model # 1194646 | 440V/60Hz, 7.5 HP, 3 Phase
- MIX 750 GAS | Model # 1194648 | 13 HP Honda GX



Model Without Motors
1194640 - Mix 750 Plus

PRODUCE 18 CUBIC FEET OF MUD EVERY THREE TO FOUR MINUTES WITH THE MIX 750

The Mix 750 is the perfect partner for busy precast mixing operations, and on bridge and highway jobs. The discharge system is easy to open and close and protected from being hit by a mud bucket or forklift. The safety grate is hinged, making access immediate. The Mix 750 is Mini-Batch Plant production for a fraction of the cost. These mixers develop vast amounts of mixing power, far more than any horizontal shaft mortar mixer. The ability to mix refractory mud or stiff, dry materials is unparalleled in the industry.



Technical specifications

POWERED by
HONDA

	MIX 360	MIX 750
Drum capacity	12 cu ft	22 cu ft
Batch output*	9 cu ft	18 cu ft
Drum diameter	38 in	52 in
Maximum aggregate size	3/8 in	3/8 in
Discharge outlet height: max/min	30/18 in	29/23 in
Pneumatic wheels	18 in	22 in
Weight: electric/gas	787/794 lbs	1,588 lbs
Electric motor rating	5 hp 220v 1ø or 3ø	5 hp 220v 1ø / 7.5 hp 220v 3ø
Gas engine*	11 hp Honda	13 hp Honda w/elec. start
Width***	44 (50) in	63 (64) in
Length***	59 (80) in	90 (86) in
Height***	58 (56) in	62 (64) in



SET UP

The stability legs slide outward to accommodate a wide variety of mud pans. They can also be adjusted up or down depending upon the desired discharge height.

These extra wide stability legs are standard on the Mix 750 and are available as an option on the Mix 360.

[*] Materials can influence the batch output [**] Warning: Cancer and Reproductive Harm - <https://www.p65warnings.ca.gov>
[***] Operating Dimensions (palletized)

15

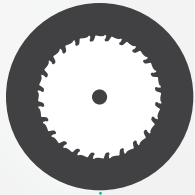

TILE, STONE, BRICK, BLOCK, SLAB SAWS

Overhead Rail Saws Stone & Slab Saws

When you need a saw that can handle it all, look no further than IMER's Combicut and Masonry series of saws. Made to be accurate, powerful and light, and comfortable in any environment, Combicut saws are used in fabrication shops to outdoor patio construction sites, small and large tile installations.

Stone and slabs keep getting bigger and bigger. High horsepower and a sturdy frame allow the Combicut series to make the cuts that other saws could only dream of. Use for precast, stone, ceramic, porcelain, brick and pavers.

The Masonry Series saws were designed for cutting bricks, blocks, and stones. Use the Masonry series for cutting of larger, bulkier materials when you need depth of cut.





COMBICUT 200 VA

TILE STONE AND PORCELAIN SAWS



COMBICUT 200 VA | Model # 1188084 | 110V/60Hz, 1.75 HP

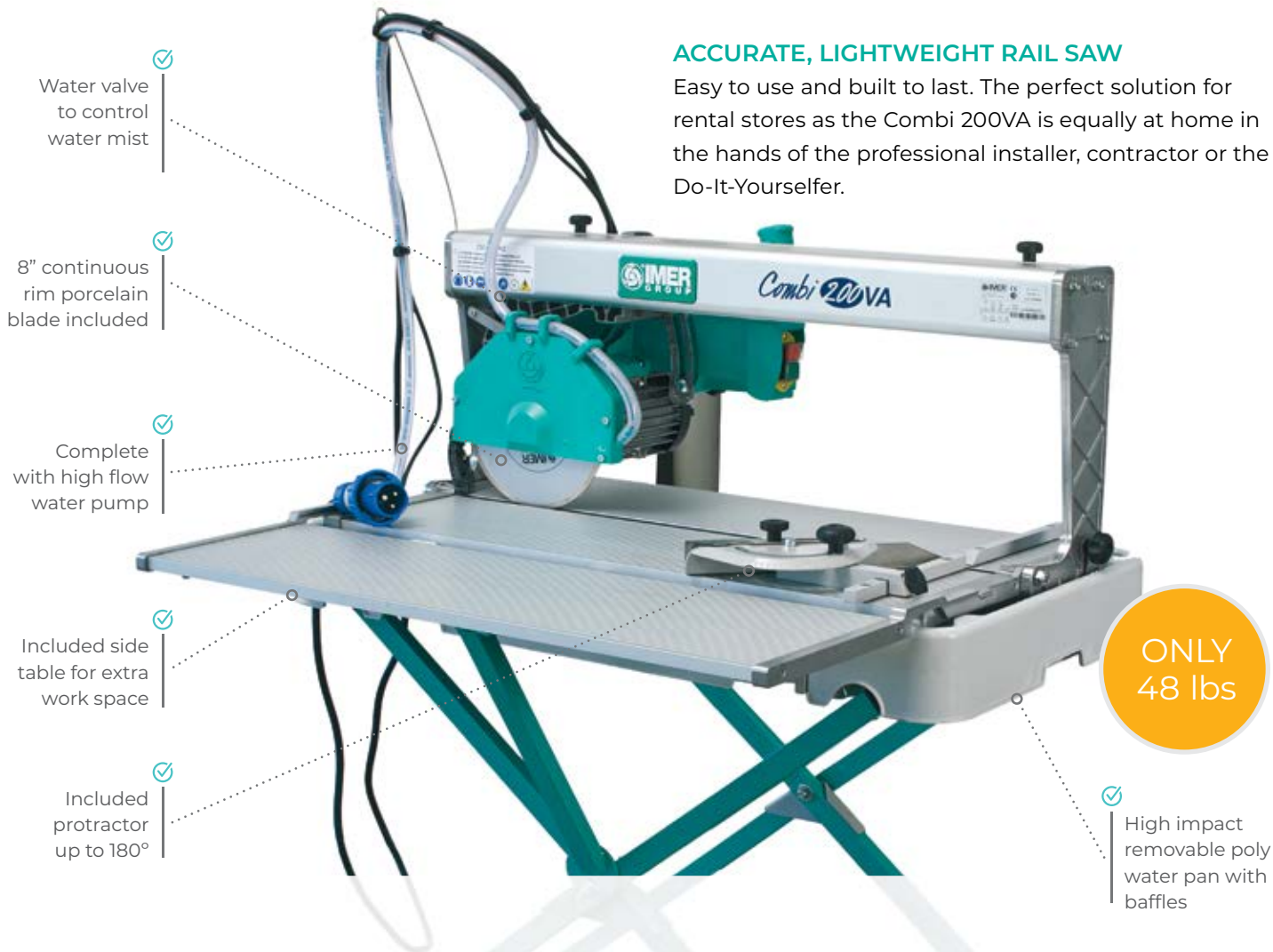

Water valve to control water mist

8" continuous rim porcelain blade included

Complete with high flow water pump

Included side table for extra work space

Included protractor up to 180°

ACCURATE, LIGHTWEIGHT RAIL SAW

Easy to use and built to last. The perfect solution for rental stores as the Combi 200VA is equally at home in the hands of the professional installer, contractor or the Do-It-Yourselfer.

ONLY 48 lbs

High impact removable poly water pan with baffles

PLUNGE CUTS

Plunge cuts are smooth and precise as the cast aluminum cutting head pivots on a sealed bushing. "L" cuts for door jams are now quick n' simple.



ACCURATE ANGLED CUTS

When 45 degree cuts are needed, just tilt the travel beam. Simple and accurate. While the overhead beam design provides a smooth accurate cut.



STAND INCLUDED



INNOVATION

The cast aluminum protractor is the only truly accurate rip guide in the industry.



TILE CLAMP FOR ACCURACY

The tile clamping system is an accessory that attaches to all Combi Series saws. Clamp down tiles and use the overhead laser to guarantee a smooth, thorough, and accurate cut. Item # 1188157



CAST ALUMINUM

The cast aluminum construction of the CombiCut VA's frame structure ensures a rigid, yet light weight saw. Out of the box it can cut tile or stone to within 1/32"

COMBICUT 250 VA

COMBICUT 250 VA | Model # 1188164 | 110V/60Hz, 1.75 HP



ACCURATE, CHIP-FREE CUTTING PERFORMANCE

A small portable tile saw with a lot of power. Compact, lightweight, and user-friendly, it is ideal for installers and DIY projects. It offers high cutting capacity: the blade is suitable for all types of material - ideal for cutting ceramic, stone materials, bricks and stone.



Water valve to control water mist

10" continuous rim porcelain blade included

Complete with high flow water pump

Included side table for extra work space

Included protractor up to 180°

Equipped with a laser guide to make cuts quickly and accurately

High impact removable poly water pan with baffles

Lightweight folding stand included

ONLY 72 lbs

Technical specifications

	COMBI 200VA 8"	COMBI 250VA 10"
Blade diameter	8 in	10 in
Blade shaft diameter	5/8 in	5/8 in
Max. cutting length (w/plunge cut)	21 (24) in	28 (31) in
Max. cutting depth	2-3/4 in	3-3/4 in
Motor rating	1.75 hp 110v, 15 amp	1.75 hp 110v, 15 amp
Blade speed	2800 rpm	2800 rpm
Weight (boxed, includes stand)	48 (68) lbs	72 (85) lbs
Water pan capacity	5 gal	10 gal
Water pump flow	3 gpm	3 gpm
Length* (boxed)	35 (37) in	40 (43) in
Height* (boxed)	19 (22) in	22 (24) in
Width* (boxed)	18 (20) in	18 (21) in
Replacement Blade - Continuous Rim	#1193920	#1193922
Replacement Blade - Abrasive Masonry	n/a	#1193932
Replacement Blade - Concrete Turbo	n/a	#1193942

(* Operating Dimensions (boxed))

PERFORMANCE

To ensure that the Combi 200VA and 250VA would be both light and powerful, we designed and developed an all new 1.75 HP motor. Cuts are made quickly and quietly. Performance and reliability are guaranteed.

EQUIPPED WITH A LASER GUIDE

A laser cutting guide comes standard with every Combicut 250VA. Mark the line of your cut on the material, line it up with the laser, and go.



COMBICUT 250 / 1000 & 1500

TILE STONE AND PORCELAIN SAWS



COMBICUT 250/1000 VA
COMBICUT 250/1500 VA

Model # 1188174
Model # 1188180

110V/60Hz, 1.75 HP
110V/60Hz, 1.75 HP

SAWS DESIGNED FOR LARGER TILE AND STONE

Precision cast aluminum, high-tech engineering, and manufacturing. IMER has created a saw which delivers superior accuracy, is lightweight, durable, and extremely reliable. Perfect for those jobs which are smaller in nature yet require cuts up to 60" in length.



PLUNGE CUTS

Plunge cuts are smooth and precise as the cast aluminum cutting head pivots on a sealed bushing. "L" cuts for door jams are now quick n' simple.



ACCURATE 45° CUTS

When 45 degree cuts are needed, just tilt the travel beam. The overhead beam design provides a smooth accurate cut. Simple and accurate.



HIGH TORQUE, LOW RPM

The 110V motor on the Combi 250VA was designed specifically for this saw. High torque at a low rpm delivers fast, chip-free cutting performance.

Our heavy-duty motors are designed to perform all day providing consistent power on each start and cut.

INNOVATION

The cast aluminum protractor is the only truly accurate rip guide in the industry.



TILE CLAMP FOR ACCURACY

The tile clamping system is an accessory that attaches to all Combi Series saws. Clamp down tiles and use the overhead laser to guarantee a smooth, thorough, and accurate cut. Item # 1188157

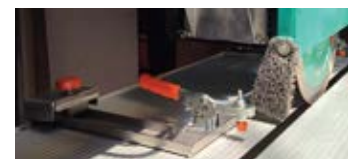

SIDE TABLE INCLUDED

The side table supports large format tiles.

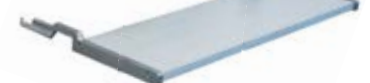

20

COMBICUT 350 iPOWER

TILE STONE AND PORCELAIN SAWS

COMBICUT 350 iPOWER | Model # 1188931 | 220V/60Hz 4 HP, Single-Phase



TILE, STONE & MASONRY SAW FOR PRECISE, LENGTHY CUTS

The 4 HP high-torque motor in the Combicut 350 iPower ensures that cuts are made quickly and accurately. Tile and stone installers, masons, precast fabricators, landscapers, and general contractors worldwide put the Combicut 350 iPower to the test every day.



Travel bar is contoured to the nylon roller bearing system for precise movement

Complete with high flow water pump

Stainless steel cutting surface - 48" cutting length

Integrated stand with wheel kit

Water pan slides out for easy cleanup

4 HP, 220V high-torque motor

14" general purpose blade included

Included protractor with 180°

Spring loaded to assist with fast set up - flip up and out of the way for transport

Technical specifications

	250/1000 VA	250/1500 VA	350 iPOWER
Blade diameter	10 in	10 in	14 in
Blade shaft diameter	5/8 in	5/8 in	1 in
Max. cutting length (w/plunge cut)	37 (40) in	57 (60) in	41-1/2 (47-1/4) in
Max. cutting depth	3-3/4 in	3-3/4 in	4-3/4 in / 2-1/4 in
Motor rating	1.75 hp 110v, 15 amp	1.75 hp 110v, 15 amp	4 hp 220v, 15 amp
Blade speed	2800 rpm	2800 rpm	2800 rpm
Weight (boxed, includes stand)	82 (98) lbs	125 (150) lbs	265 (300) lbs
Water pan capacity	12 gal.	13 gal.	9 gal.
Water pump flow	3 gpm	3 gpm	--
Length* (boxed)	55 (58) in	76 (77) in	69 (70) in
Height* (boxed)	24 (26) in	24 (26) in	55-1/2 (60-1/2) in
Width* (boxed)	25 (27) in	25 (27) in	30 (30-1/2) in
Replacement Blade - Continuous Rim	#1193922	#1193922	#1193924
Replacement Blade - Abrasive Masonry	#1193932	#1193932	#1193934
Replacement Blade - Concrete Turbo	#1193942	#1193942	#1193944
Replacement Blade - Stone	n/a	n/a	#1193954

(* Operating Dimensions (boxed))

POWER

The motor in the COMBI 350 iPOWER is a high-torque 4 hp 220V Single-Phase stone and paver eating machine. All this power goes from the motor to the blade via a high tech serpentine belt. No adjustment or maintenance required, it is a tough and reliable design.



MASONRY 350 SMART

BRICK AND BLOCK SAW



MASONRY 350 | Model # 1188975 | 115V/60Hz, 2 HP

THE BEST SOLUTION FOR CUTTING BRICKS, BLOCKS, PAVING STONES, OR TILE

The biggest cutting table available on a 14" masonry saw. The Masonry 350 delivers very accurate cuts up to 30" in length and 4 3/4" deep. The 2 HP motor provides the power required to cut through larger and longer pieces day in and day out.



- ✓ 2 HP, 115V high-torque motor
- ✓ 14" general purpose blade included
- ✓ 180° protractor included
- ✓ Integrated stand with wheel kit

- ✓ Single arm design allows for larger cuts
- ✓ The cutting tray rolls back and forth on ceramic nylon rollers with sealed bearings
- ✓ Includes wheelkit and a springloaded folding stand for easy transport

Technical specifications

MASONRY 350 SMART CUT

Blade diameter	14 in
Blade shaft diameter	1 in
Max. cutting length - includes plunge	26 (30 in)
Max. cutting depth	4-3/4 in
Motor	2 hp 115v, 15 amps
Cutting table dimensions	20 in x 16 in
Cutting surface height	33-1/2 in
Motor speed	2850 rpm
Weight* (boxed)	175 (215) lbs
Water pan capacity	10 gal
Water pump flow	3 gpm
Length* (boxed)	47 (48) in
Height* (boxed)	51 (55) in
Width* (boxed)	28-1/2 (29) in
Replacement Blade - Continuous Rim	#1193924
Replacement Blade - Abrasive Masonry	#1193934
Replacement Blade - Concrete Turbo	#1193944
Replacement Blade - Stone	#1193954

INNOVATION

The blade guard is lined with sound absorbing material used in the boat building industry, and this greatly reduces noise from the blade. The blade guard may be removed with just two thumb screws - changing blades is fast and easy.



MITER CUT ACCESSORIES

If your work requires you to make 45 degree miter cuts, we have developed an accurate and easy-to-use miter for the Masonry 350 and Masonry 750 saws.

Masonry 350, Item # 1187640
Masonry 750, Item # 1188870

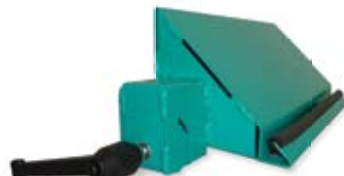

(*) Operating Dimensions (boxed)

MASONRY 750 PLUS

BLOCK, STONE AND PRECAST SAW

MASONRY 750 | Model # 1188863 | 220V/60Hz, 5.5 HP, Single-Phase
 MASONRY 750 | Model # 1188864 | 220V/60Hz, 7.5 HP, 3 Phase



THE ERGONOMIC 30" BLADE STONE SAW HANDLES BIG BLOCK AND STONE

The Masonry 750 Plus allows operators to cut 8" and 10" blocks in a single pass – without the added hassle and effort of a foot pedal. The powerful 7.5 hp electric motor combined with the 30" blade delivers 12" of cutting depth. Cut through blocks, pavers, and pre-cast concrete products with ease. The frame and cutting tray are hand fabricated using heavy-duty steel, while the ergonomic design allows the operator to transport the saw with little effort.



Hands are protected for maximum safety

Locking wheels to move around the job site

1 \emptyset or 3 \emptyset , 220V electric motor options

Add the 20" kit to convert to a 20" blade

Heavy duty tray to support heavy loads

Fork lift pockets for loading and unloading

Technical specifications

MASONRY 750 PLUS	
Blade diameter	30 in
Blade shaft diameter	1 in
Max. cutting length - includes the plunge	18 / 27 in
Motor rating	5.5 hp 220v, 1 \emptyset or 7.5. hp 220v, 3 \emptyset
Blade speed	1700 rpm
Weight (crated)	440 (495) lbs
Water pan capacity	9 gals
Self-priming centrifugal pump	3 g.p.m.
Length* (boxed)	61 in
Height* (boxed)	63 in
Width* (boxed)	33- $\frac{1}{2}$ in
Replacement Blade - Masonry Block	#1193957

(* Operating Dimensions (boxed)

VERSATILITY

Should it be necessary to make a plunge cut just grab the tilt handle and ease the blade into the material. The cutting head pivots on sealed bearings, making plunge cuts is smooth and controlled.

EASE OF USE

The Masonry 750 is designed to make it easier to move the blocks on and off the saw. The lower profile allows the operators to get a lot more done in a day.

QUALITY

The box steel frame is very rigid yet light for a saw of this size. Proven design techniques combined with high-quality steel makes for one powerful machine.



POWER

The 30" blade begins to spin very efficiently as the optional 7.5HP motor is equipped with an electronic soft start system.

PORTABILITY

The wheelkit and the well engineered balance of the saw allow it to be rolled around by one person. Easily handled by a forklift as lift slots are welded into a frame.

SAW BLADES & ACCESSOR

TILE, STONE, MASONRY, AND HARD MATERIAL



IMER SAW - REPLACEMENT SAW BLADES

IMER STANDARD AND PREMIUM SAWBLADES PROVIDE ACCURATE, CHIP-FREE CUTTING PERFORMANCE

From thick stone and block to large ceramic tile, porcelain and stone pieces, IMER saw blades are designed exclusively for IMER saws — only using the highest-quality diamonds, metals and aggregates to provide accurate, professional-grade cuts again and again. The preferred saws and blades of masons, tile professionals, and rental companies worldwide.



CONTINUOUS RIM TILE BLADES

SIZES: 8" | 10" | 14"

IMER's continuous rim blades are designed to cut Ceramic tile, Porcelain and Stone. Continuous rim blades are best for accurate, chip-free cutting performance, essential for cosmetic appearance.

PART # **BLADE**

1193920 8" x .060 Continuous Rim Porcelain & Hard Materials

1193922 10" x .060 Continuous Rim Porcelain & Hard Materials

1193924 14" x .090 Continuous Rim Porcelain & Hard Materials



SEGMENTED PREMIUM MASONRY BLADES

SIZES: 10" | 14" | 20" | 30"

IMER's premium segmented blades are designed specifically for abrasive masonry applications such as Block, Brick, Sandstone, and Soft Stone.

PART # **BLADE**

1193932 10" x .110 Segmented Premium Masonry

1193934 14" x .125 Segmented Premium Masonry

1193938 20" x .155 Segmented Premium Masonry*

1193913 30" x .165 Full Segmented Premium Masonry

1193957 30" x .165 Segmented Premium Masonry



CONCRETE TURBO BLADES

SIZES: 10" | 14" | 20"

IMER's hard masonry turbo blades are designed to handle a multitude of applications starting with Concrete, Block, Brick, Paver Brick, Hard Brick, Masonry, Natural Stone, Refractory Material, Artificial Stone, Sandstone, Soft Stone, Stone.

PART # BLADE

1193942 10" x .110 Concrete Turbo with Teardrop Gullets

1193944 14" x .125 Concrete Turbo with Gullets

1193948 20" x .160 Concrete Turbo with Teardrop Gullets*

*Conversion kit required

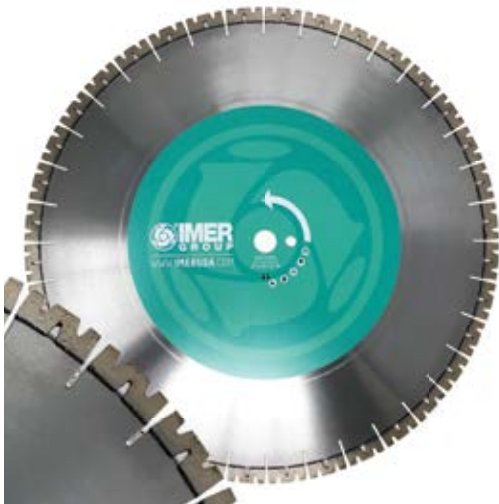

STONE / HARD APPLICATION PREMIUM BLADES

SIZES: 14" | 20" | 30"

IMER's premium diamond blades are built to tackle Block, Brick, Paver Brick, Hard Brick, Masonry, Natural Stone, Refractory Material, Artificial Stone, Sandstone, Soft Stone, Stone. The silent core on the 14" reduces noise.

PART # BLADE

1193954 14" x .125 Silent Core for Stone

1193956 20" x .165 Stone Cutting Blade*

1193958 30" x .165 Stone Cutting Blade

1193941 30" x .170 Premium Stone Cutting Blade

*Conversion kit required

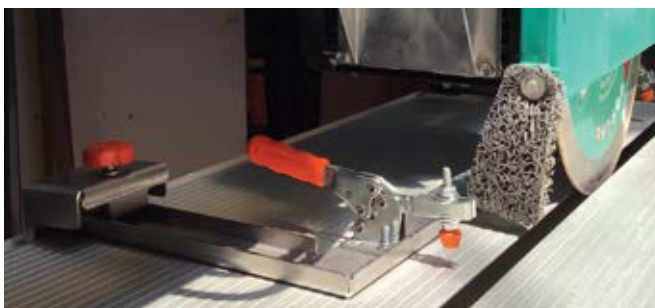

TILE CLAMP FOR ACCURACY

The tile clamping system is an accessory that attaches to all Combicut Series saws. Clamp down tiles and use the overhead laser to guarantee a smooth, thorough, and accurate cut.

Item # 1188157

CARRY DUMPERS



GAS & ELECTRIC POWERED TRACKED TRANSPORTERS

KATO-IMER's Track Driven Powered Mini-dumpers and Buggies are the ideal solutions to transport and handle various types of materials and provide excellent traction on grades, inclines, and soft soils. Gas and Diesel powered options are designed to tackle larger outdoor projects. The award-winning electric mini-dumper is perfect for indoor situations when fumes and noise need to be considered or are mandatory.

From mini-dumpers to lift and haul smaller materials to larger buggies with a 180-degree pivoting dump, the family of versatile machines can be equipped with a wide range of accessories, which may be easily changed by the quick and simple equipment coupling/uncoupling system.

Each machine is designed with the comfort and safety of the operator in mind. Added safety features and ergonomic designs help the operator be more productive and stay safe throughout the workday. When an operator stops, even in a state of idling, the machine stops.

The control consoles on each machine are simple and intuitive, and a control lever protection bar is a convenient armrest for the operator, while the control levers are connected directly to the control valve to ensure an accurate, progressive response.

Each day, KATO-IMER engineers are working to develop new models and attachments to make work easier, and safer.



KATO IMER
THINK GLOBAL, ACT LOCAL



CARRY 107

GAS POWERED TRACKED MINI-DUMPER



CAPACITY
11.6 CU FT

CARRY 107 - TIPPING BUCKET

Model # 5221110001

11 HP Honda GX

A COMPACT, YET POWERFUL TRACKED DUMPER BOASTS A 11HP HONDA ENGINE WITH AN EASY ELECTRIC START

The Carry 107 mini-dumper is the ultimate 1-person ride-on hauler. Designed with a compact 30" width to fit through the narrowest of backyard gates or interior doors. While conventional buggies and tracked machines do not offer an extendible undercarriage, the rubber tracks on the Carry 107 can extend from 30" to nearly 42" in width to provide the added stability required on challenging job sites with hills and uneven slopes, plus the extended track provides added protection to lawns and floors preventing unwanted damage.



30" Width

42" Extendible Undercarriage

Intuitive controls with reduced vibration for operator comfort

Hydraulic power take-off provides added power for speed and inclines

Ergonomically designed footplate structure prevents vibration to operator

Narrow 30" width to fit through standard doors and gates



Steel 11.6 cubic foot bucket and 1,543 lb operating load

Change attachments easily with the "quick coupling" system

SAFETY AND STANDARDS

The Honda engine is low noise, which meets established noise pollution standards. The engine is mounted on vibration dampers to significantly reduce the amount of vibration transmitted.



EASY TO USE CONTROLS

Uncluttered, convenient, and intuitive controls allow for easy 1 person operation. The surrounding grab bars provide the operator added safety when driving and a convenient armrest when idling.



Technical specifications

POWERED by
HONDA

CARRY 107	
Engine*	Honda GX390, 11 hp
Machine weight 107 / 107 HT	950 lbs / 1510 lbs
Operating load	1543 lbs
Payload capacity	11.6 cu ft
Speed	2.5 mph
Max allowed slope when empty	15° - 26%
Max allowed slope when loaded**	7° - 12%***
Ground clearance	4 in
Start	Electric
Length	72 in
Height	44-½ in
Width	30 in

(*) Warning: Cancer and Reproductive Harm - <https://www.p65warnings.ca.gov>

(**) Guide with operator on the ground, where applicable (***) Variable based on the configuration

CARRY 107 ATTACHMENTS

CARRY 107 - GAS POWERED HI-TIP TRACKED MINI-DUMPER AND MORE

SELF-LOADING SHOVEL	Model # 5180101010HD
DUMP PLATFORM WITH OPENING SIDES	Model # 5180101012HD
CONCRETE MIXER L 250 KIT AND SELF-LOADING SHOVEL	Model # 5180102012HD
LEVELLING BLADE KIT	Model # 5180100029HD
HIGH TIP BUCKET & SELF-LOADING SHOVEL KIT	Model # 5180101602HD



ACCESSORY KITS PROVIDE ADDED VERSATILITY AND ROI

The Carry 107 mini-dumper offers a full range of attachments that handle every aspect of material handling and multiple applications. Easily convert one machine into six different machines - including a Self-loading Shovel, Dump Platform, Concrete Mixer with Self-loading Shovel, Levelling Blade, and the Hi-Tip Bucket and Self-loading Shovel kit.



1

SELF-LOADING SHOVEL

Model # 5180101010HD

Attach the hydraulic-powered self-loading shovel to easily scoop, move, and drop multiple materials like stone, gravel, mulch, and dirt, not to mention job site cleanup.

2

LEVELLING BLADE

Model # 5180100029HD

Once you are finished moving material, the levelling blade is the perfect solution for levelling gravel, and stone for driveways, walkways and patios. The swivelling blade makes a great tool for pushing snow off parking lots and walkways.

3

CONCRETE MIXER WITH SELF-LOADING SHOVEL

Model # 5180102012HD

The concrete mixer and hydraulic-powered self-loading shovel are a unique solution for mixing and pouring concrete in hard-to-reach areas. Use the shovel to load dry material into the mixer, or use it to gently place wet material.

4

HI-TIP BUCKET WITH SELF-LOADING SHOVEL

Model # 5180101602HD

The "Hi-Tip" attachment hydraulically lifts materials in the steel 11.6 cubic foot bucket to an unloading/loading height of 63". The kit includes the self-loading shovel.

5

DUMP PLATFORM

Model # 5180101012HD

The three folding sides on the dump platform presents multiple possibilities for moving everything from logs and large rocks to drywall and lumber.

CARRY 105

GAS POWERED TRACKED MINI-DUMPER



CAPACITY
8 CU FT

CARRY 105 GAS - TIPPING BUCKET | Model # 5222310001HD | 8 HP Honda GX

LOAD N' GO SMALL, VERSATILE MACHINE

The new Carry 105 mini-dumper is a highly agile and versatile machine, small in size, yet able to handle a large load on all kinds of terrain, including steep gradients. The Carry 105 Gas and Electric standard models include a steel Tipping Bucket. The Carry 105 mini-dumpers may be equipped with a wide range of accessories to meet various requirements, including the Self-loading Shovel, or the Dumping Platform Bed with Opening Sides.



SAFETY AND STANDARDS

The Honda engine is low noise, which meets established noise pollution standards. The engine is mounted on vibration dampers to significantly reduce the amount of vibration transmitted.



OPTIONAL DUMP PLATFORM WITH OPENING SIDES

Model # 5180301002HD

The dump platform accessory is perfect for transporting and unloading bulky materials from 3 sides of the platform bed.



Technical specifications

POWERED by **HONDA**

CARRY 105	
Engine*	Honda GX200, 6.5 hp
Machine weight	640 lbs
Operating load	1,102 lbs
Payload capacity	8 cu ft
Speed	2 mph
Max allowed slope when empty	20° - 36%
Max allowed slope when loaded**	11° - 20%***
Ground clearance	4 in
Start	Electric
Length	62-½ in
Height	44-½ in
Width	27 in

(*) Warning: Cancer and Reproductive Harm - <https://www.p65warnings.ca.gov>
 (**) Guide with operator on the ground, where applicable (***) Variable based on the configuration

CARRY 105 ELECTRIC

ELECTRIC POWERED TRACKED MINI-DUMPER

CARRY 105 E - TIPPING BUCKET | Model # 5222210001HD | Electric



ECOLOGICAL WITHOUT COMPROMISE

The electric power Carry 105 mini-dumper is the ideal solution to satisfy the requirements of handling materials in closed spaces and indoor job sites, and sensitive places such as schools, hospitals and in rooms with little ventilation, where it is essential to work without gases, fumes or noise.



**INTERMAT
INNOVATION
AWARD
WINNER**



Technical specifications

CARRY 105E	
Engine / Motor	Electric
Power	2.95 hp
Batteries	Lithium-Iron-Phosphate (Li-Fe-PO4) 90 Ah 36V rated batteries
Battery life (continuous operation)	2.5 hrs
Operating load	882 lbs
Payload capacity	7.77 cu ft
Speed	2 mph
Basic machine weight	716 lbs
Payload weight	110 lbs
Bucket weight with shovel	231 lbs
Bed weight	143.3 lbs

(*) Guide with operator on the ground, where applicable (**) Variable based on the configuration

SIMPLE, INTUITIVE CONTROLS

The control console is simple and intuitive. The control lever protection bar is a convenient armrest for the operator, while the control levers are connected directly to the control valve to ensure an accurate, progressive response.



SELF-LOADING SHOVEL

Model # 5180301001HD

The self-loading shovel makes job site cleanup and moving gravel, stone, and mulch easier and more cost-effective.

HIGH EFFICIENCY

The machine automatically goes into stand-by when not running, providing high power with long service life. Its wear-resistant construction and modular design makes maintenance quick and easy.

CARRY 107

GAS POWERED TRACKED MINI-DUMPER



CAPACITY
11.6 CU FT

CARRY 107 - TIPPING BUCKET | Model # 5221110001 | 11 HP Honda GX

A COMPACT, YET POWERFUL TRACKED DUMPER BOASTS A 11HP HONDA ENGINE WITH AN EASY ELECTRIC START

The Carry 107 mini-dumper is the ultimate 1-person ride-on hauler. Designed with a compact 30" width to fit through the narrowest of backyard gates or interior doors. While conventional buggies and tracked machines do not offer an extendible undercarriage, the rubber tracks on the Carry 107 can extend from 30" to nearly 42" in width to provide the added stability required on challenging job sites with hills and uneven slopes, plus the extended track provides added protection to lawns and floors preventing unwanted damage.



30" Width

42" Extendible Undercarriage

Intuitive controls with reduced vibration for operator comfort

Hydraulic power take-off provides added power for speed and inclines

Ergonomically designed footplate structure prevents vibration to operator

Narrow 30" width to fit through standard doors and gates



Steel 11.6 cubic foot bucket and 1,543 lb operating load

Change attachments easily with the "quick coupling" system

SAFETY AND STANDARDS

The Honda engine is low noise, which meets established noise pollution standards. The engine is mounted on vibration dampers to significantly reduce the amount of vibration transmitted.



EASY TO USE CONTROLS

Uncluttered, convenient, and intuitive controls allow for easy 1 person operation. The surrounding grab bars provide the operator added safety when driving and a convenient armrest when idling.



Technical specifications

POWERED by **HONDA**

CARRY 107	
Engine*	Honda GX390, 11 hp
Machine weight 107 / 107 HT	950 lbs / 1510 lbs
Operating load	1543 lbs
Payload capacity	11.6 cu ft
Speed	2.5 mph
Max allowed slope when empty	15° - 26%
Max allowed slope when loaded**	7° - 12%***
Ground clearance	4 in
Start	Electric
Length	72 in
Height	44-½ in
Width	30 in

(*) Warning: Cancer and Reproductive Harm - <https://www.p65warnings.ca.gov>

(**) Guide with operator on the ground, where applicable (***) Variable based on the configuration

CARRY 107 ATTACHMENTS

CARRY 107 - GAS POWERED HI-TIP TRACKED MINI-DUMPER AND MORE

SELF-LOADING SHOVEL | Model # 5180101010HD

DUMP PLATFORM WITH OPENING SIDES | Model # 5180101012HD

CONCRETE MIXER L 250 KIT AND SELF-LOADING SHOVEL | Model # 5180102012HD

LEVELLING BLADE KIT | Model # 5180100029HD

HIGH TIP BUCKET & SELF-LOADING SHOVEL KIT | Model # 5180101602HD



ACCESSORY KITS PROVIDE ADDED VERSATILITY AND ROI

The Carry 107 mini-dumper offers a full range of attachments that handle every aspect of material handling and multiple applications. Easily convert one machine into six different machines - including a Self-loading Shovel, Dump Platform, Concrete Mixer with Self-loading Shovel, Levelling Blade, and the Hi-Tip Bucket and Self-loading Shovel kit.

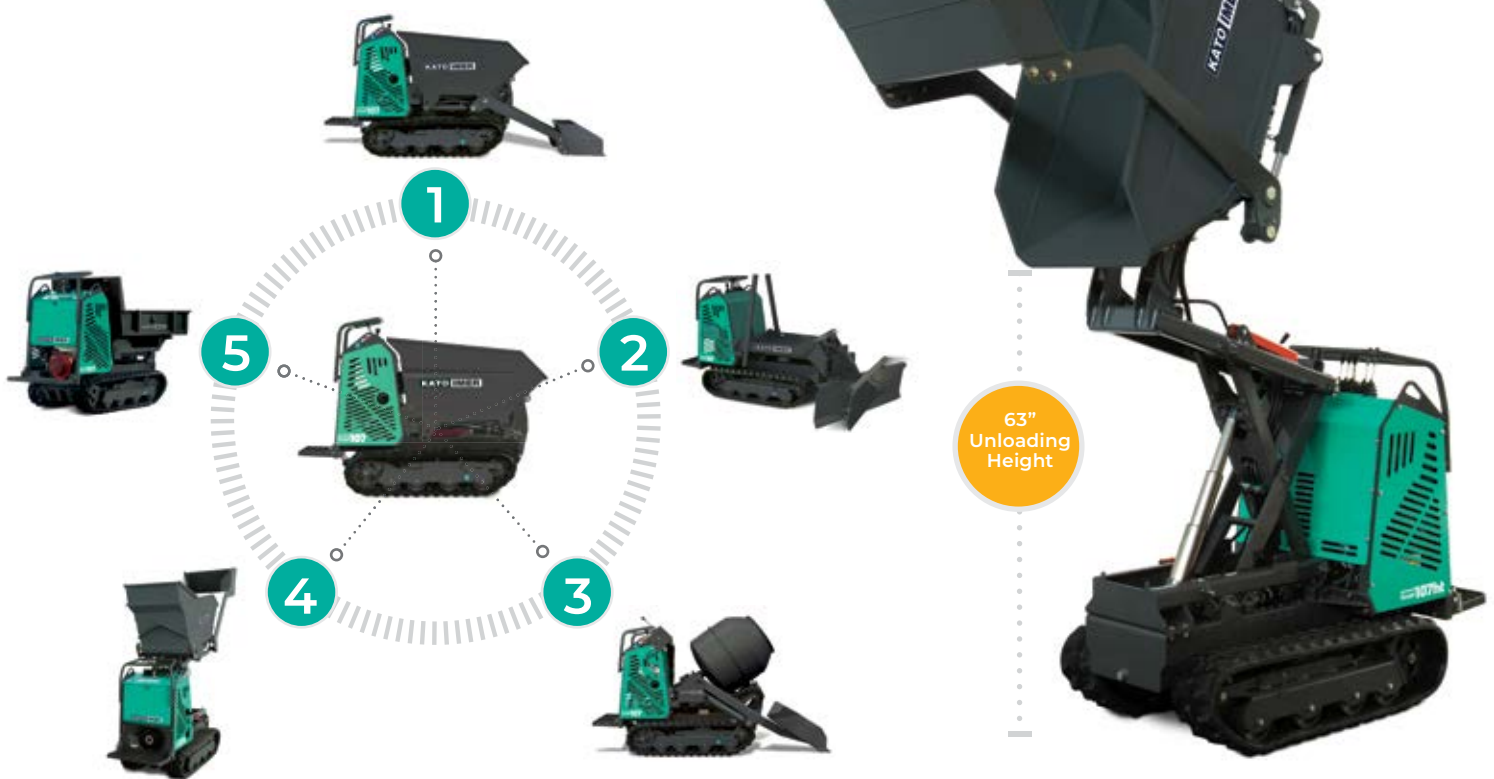

1

SELF-LOADING SHOVEL

Model # 5180101010HD

Attach the hydraulic-powered self-loading shovel to easily scoop, move, and drop multiple materials like stone, gravel, mulch, and dirt, not to mention job site cleanup.

2

LEVELLING BLADE

Model # 5180100029HD

Once you are finished moving material, the levelling blade is the perfect solution for levelling gravel, and stone for driveways, walkways and patios. The swiveling blade makes a great tool for pushing snow off parking lots and walkways.

3

CONCRETE MIXER WITH SELF-LOADING SHOVEL

Model # 5180102012HD

The concrete mixer and hydraulic-powered self-loading shovel are a unique solution for mixing and pouring concrete in hard-to-reach areas. Use the shovel to load dry material into the mixer, or use it to gently place wet material.

4

HI-TIP BUCKET WITH SELF-LOADING SHOVEL

Model # 5180101602HD

The "Hi-Tip" attachment hydraulically lifts materials in the steel 11.6 cubic foot bucket to an unloading/loading height of 63". The kit includes the self-loading shovel.

5

DUMP PLATFORM

Model # 5180101012HD

The three folding sides on the dump platform presents multiple possibilities for moving everything from logs and large rocks to drywall and lumber.

33

CARRY 108HF

GAS POWERED TRACKED MINI-DUMPER



CAPACITY
13 CU FT

CARRY 108 HF - TIPPING BUCKET & SELF-LOADING SHOVEL | Model # 5223213101 | 11 HP Honda GX

HIGH FLOW MEANS HIGH-PERFORMANCE, POWERFUL, AND FUNCTIONAL

The Carry 108HF high performance mini-dumper is a powerful, yet compact machine, engineered with four pumps to provide a high oil flow rate to increase speed, and to drive attachments that require increased power for heavier projects, such as brush-cutting and snow removal. The Carry 108HF coupling/uncoupling system makes changing attachments quick and simple. While the tracks supply power and stability on the ground, the float function prevents attachments from bouncing, providing additional stability and safety for the operator, especially on uneven or sloping terrains. The standard Carry 108HF unit includes the tipping bucket and self-loading shovel (shown right).



Easy to use coupling/uncoupling system

Float Control design reduces bouncing for added safety



BRUSH-CUTTING ATTACHMENT

Model # 5180104300

The powerful Carry 108 High Performance tracked machine with the brush-cutting attachment is ideal for mowing river banks, road verges, and shredding brush.



SNOW BLOWER ATTACHMENT

Model # 5180104700

The snow blower attachment is designed to easily remove snow from roads, paths, pavements, industrial sites, and more. The machine's tracks provide the power to plow through heavy



Technical specifications

POWERED by
HONDA

CARRY 108HF	
Engine*	Honda GX390, 11 hp
Machine weight	1,329 lbs
Operating load	1,764 lbs
Payload capacity	13 cu ft
Speed	3 mph
Max allowed slope when empty	20° - 30%
Max allowed slope when loaded**	7° - 12%***
Ground clearance	3 in
Start	Electric
Length	72 in
Height	106 in
Width	30 in

(*) Warning: Cancer and Reproductive Harm - <https://www.p65warnings.ca.gov>
 (**) Guide with operator on the ground, where applicable (***) Variable based on the configuration

CARRY 150

DIESEL POWERED 180° SWIVEL TRACKED DUMPER

CARRY 150 - 180° SWIVELLING BUCKET | Model # 5240304101 | 20HP Kubota Diesel



POWER, SPEED AND 180° SWIVEL DUMP

The Carry 150 has an independent dual circuit hydrostatic transmission with a variable displacement axial piston pump and a dual displacement axial piston hydraulic engine for each track. The standard Carry 150 model offers a 180° trilateral hydraulic lift and swivel bucket to handle a multitude of loading/unloading options.



✓ 28 cubic foot bucket capacity

✓ 180° trilateral load/unloading with hydraulic lift and swivel

✓ Spacious ground clearance and rubber tracks provide greater mobility and higher speeds

✓ Foldable ROPS for operator protection

✓ Adjustable operator seat in central rear position with access from both sides

✓ Abundantly oversized Kubota 20 HP engine

✓ Battery housing under engine bonnet

Technical specifications



CARRY 150

Engine* - Diesel	Kubota D902, 20 hp
Machine weight	1,896 lbs
Operating load	3,307 lbs
Payload capacity	28 cu ft
Speed	5 mph
Max allowed slope when empty	32° - 62%
Max allowed slope when loaded**	32° - 62%***
Ground clearance	9-½ in
Start	Electric
Length	107 in
Height	93-¾ in
Width	42-½ in

INTUITIVE CONTROLS

The control panel is easy to access and operate. Drive and operate the Carry 150 from the protected operator's seat located behind the swivelling bucket.



HI-TIP SELF-LOADING SHOVEL AND BUCKET KIT OPTION

Model # 5250315101

The Carry 150 offers a "Hi-Tip" Tipping Bucket & Self-loading Shovel kit. The variable height scissor lifting bucket can lift and dump materials up to 75".

(*) Warning: Cancer and Reproductive Harm - <https://www.p65warnings.ca.gov>
 (**) Guide with operator on the ground, where applicable (***) Variable based on the configuration

35

CARRY 230

DIESEL POWERED ALL-TERRAIN 180° SWIVEL TRACKED CRAWLER



CAPACITY
41.3 CU FT

CARRY 230 - 180° SWIVELLING BUCKET | Model # 5240334101HD | 24.8HP Kubota Diesel

THE LARGEST BUCKET IN THE FLEET BOASTING 180° CAPABILITY

The Carry 230 tracked dumper is the most powerful machine in the IMER fleet. With a 24.8 HP Kubota Diesel engine, hydraulic transmission, 10-½" wide tracks, and a 41 cubic foot steel bucket, the Carry 230 is built to move and unload a multitude of material like concrete and stone quickly and efficiently.



41+ cubic foot bucket capacity

Bucket with 180° trilateral unloading with hydraulic lift and swivel

Spacious ground clearance and rubber tracks provide greater mobility at higher speeds

Foldable ROPS for operator protection

Adjustable operator seat in central rear position with access from both sides

Easy access to the Kubota 24.8 HP engine, transmission and more

Battery housing under engine bonnet

EASY TO USE CONTROLS

Uncluttered, convenient and intuitive controls allow for easy 1 person operation. Ergonomic seating and control design provides added operator comfort.



SELF-LOADING SHOVEL AND BUCKET KIT OPTION

Model # 5240335101HD

The Carry 230 Trilateral Tipping Bucket & Self-loading Shovel kit scoops and dumps from multiple positions.



Technical specifications

Kubota

CARRY 230

Engine* - Diesel	Kubota V1505, 24.8 hp
Operating weight	5,038 lbs
Operating load	5,070 lbs
Payload capacity	41.3 cu ft
Speed	5 mph
Max allowed slope when empty	25° - 46%
Max allowed slope when loaded**	21° - 38%***
Ground clearance	9-¾ in
Start	Electric
Length	127-¼ in
Height	99-¾ in
Width	51 in

(*) Warning: Cancer and Reproductive Harm - <https://www.p65warnings.ca.gov>
 (**) Guide with operator on the ground, where applicable (***) Variable based on the configuration

EZEE CLEAN

MORTAR AND CONCRETE EQUIPMENT & TOOL CLEANER

EZEE CLEAN

Model # L000014
Case (12 - 22oz
Bottles)

Model # L000013
5 Gallon Container



BEST VALUE
5 GALLON



CONCRETE CLEAN UP MADE EASY

EZEE Clean is a superb all-natural non-toxic Mortar and Concrete Dissolver designed to melt away any type of cementitious material, whether concrete, stucco, mortar, or grout.

Use on mixers and pumps after each use. Save labor cleaning tools and equipment, and save your equipment from the damage hammers and chisels cause.

EZEE CLEAN, EZEE TO USE

Soak the buildup, let EZEE Clean work awhile, hit it once or twice with a brush and wash it away.

Dilute and neutralize with only water.



100% biodegradable "green" product



Contains No muriatic, sulfuric, or phosphoric acids



Will not harm painted surfaces, metal, plastic, plants or vegetation



Dilute and neutralize with only water

BEFORE



AFTER



EZEE CLEAN REMOVES:

- Cured concrete
- Mortar
- Stucco
- Grout
- Thin set
- Efflorescence from pavers and bricks

EZEE CLEAN WORKS ON:

- Trowels
- Mixers
- Shovels
- Wheelbarrows
- Mud Tubs
- Pumps
- Molds
- Forms
- Concrete Saws
- Cement trucks
- Augers
- Conveyors
- Scaffold
- Silos
- Aerial Lifts
- Wall and Deck Splashes

37

CARRY 230

DIESEL POWERED ALL-TERRAIN 180° SWIVEL TRACKED CRAWLER



CAPACITY
41.3 CU FT

CARRY 230 - 180° SWIVELLING BUCKET | Model # 5240334101HD | 24.8HP Kubota Diesel

THE LARGEST BUCKET IN THE FLEET BOASTING 180° CAPABILITY

The Carry 230 tracked dumper is the most powerful machine in the IMER fleet. With a 24.8 HP Kubota Diesel engine, hydraulic transmission, 10-½" wide tracks, and a 41 cubic foot steel bucket, the Carry 230 is built to move and unload a multitude of material like concrete and stone quickly and efficiently.



EASY TO USE CONTROLS

Uncluttered, convenient and intuitive controls allow for easy 1 person operation. Ergonomic seating and control design provides added operator comfort.



SELF-LOADING SHOVEL AND BUCKET KIT OPTION

Model # 5240335101HD

The Carry 230 Trilateral Tipping Bucket & Self-loading Shovel kit scoops and dumps from multiple positions.



Technical specifications



CARRY 230

Engine* - Diesel	Kubota V1505, 24.8 hp
Operating weight	5,038 lbs
Operating load	5,070 lbs
Payload capacity	41.3 cu ft
Speed	5 mph
Max allowed slope when empty	25° - 46%
Max allowed slope when loaded**	21° - 38%***
Ground clearance	9-¾ in
Start	Electric
Length	127-¼ in
Height	99-¾ in
Width	51 in

(*) Warning: Cancer and Reproductive Harm - <https://www.p65warnings.ca.gov>
 (**) Guide with operator on the ground, where applicable (***) Variable based on the configuration

IMER PARTS - ONLINE SUPPORT

ONE WEBSITE. ALL PARTS.

The new IMER Parts website has been launched offering customers the ability to search for parts by the part number, description or serial number, then easily locate the parts you need using the 3-D exploded view of the equipment diagrams. This website also includes a section for equipment user guides and manuals, and a Help Desk.

Get started today. Log in, create your account, and enjoy ordering parts, made easy.

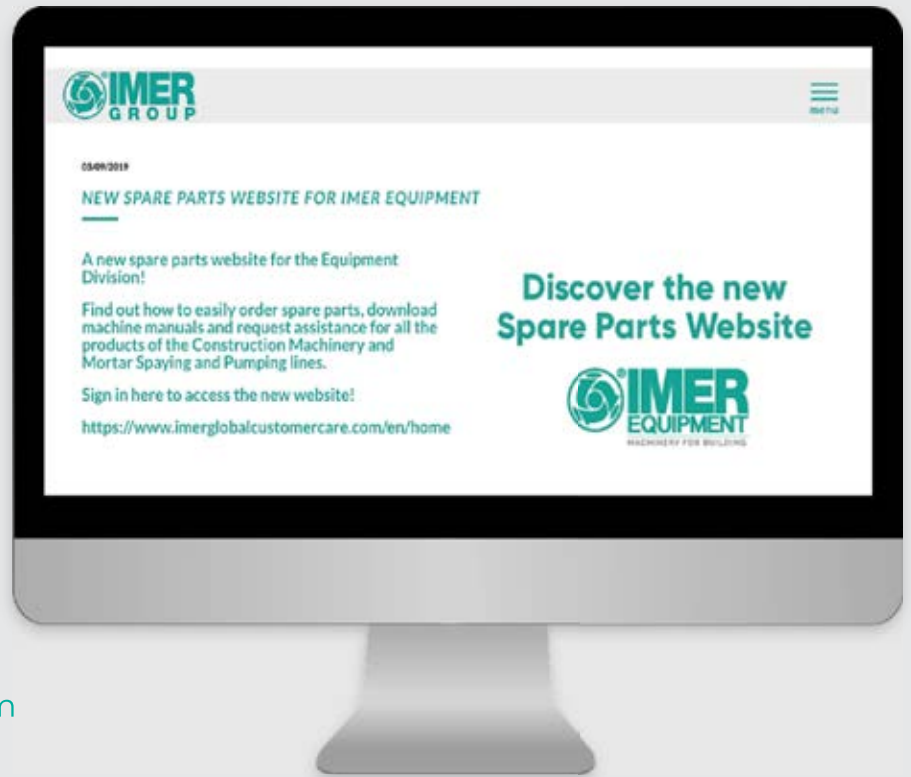

www.imerglobalcustomercare.com

IMER SUPPORT

GOT QUESTIONS?
Call Us Toll-Free (800) 275-5463

Call our toll-free phone number to speak to an IMER Representative regarding Sales, Customer Service, or Parts.

We can also help you locate a dealer, a service center, or a sales representative closest to you.



IMER-GROUP-EQUIP-220525-USA

TOLL FREE: 800.275.5463
WWW.IMERUSA.COM



IMER USA, Inc.
423 Bank Street, Suite 180
Southlake, TX 76092
Tel. (800) 275-5463 - Fax (301) 336-6687
www.imerusa.com



IMER Group | USA (IMER USA, Inc) reserves the right to change the information contained herein without prior notice when considered justified. The data and dimensions are not to be considered as binding. The illustrations may include accessories and could be slightly different from the standard versions of the equipment.

© Copyright by IMER Group | USA